

RFM98P/RFM95P

Enhanced Power Long Range Transceiver Module

(The purpose of this RFM98P/RFM95P spec covers mainly for the hardware and RF parameter info of the module, For software info please refer to RF98/RF96 chip datasheets and demo program of HopeDuino™ Development Kit)

1. General Introduction

RFM98P/RFM95P module series' design is based on the high performance LoRa™ modulation technique RF98/RF96 chip, It operate at 169/433/470MHz(RFM98P and 868/915MHz(RFM95P) ISM band , The low receive sensitivity(-136dBm) coupled with Enhanced +30dBm output power ensures extended range and improved link performance.



2. Features:

- LoRa™ Modem.
- 166dB maximum link budget.
- +30 dBm output power @433/470MHz band; +27 dBm output power @169 /868/915 MHz band.
- Programmable bit rate up to 300 kbps.
- High sensitivity: down to -136dBm.
- Low RX current of 13mA.
- FSK, GFSK, MSK, GMSK, LoRa™ and OOK modulation.
- Built-in bit synchronizer for clock recovery.
- Automatic RF Sense and CAD with ultra-fast AFC.
- Packet engine up to 256 bytes with CRC.
- Built-in temperature sensor and low battery indicator.
- SMD Package (35.4x18X3.85mm)

3. Typical Application:

- Long Range system
- Meter Reading
- Wireless data collection
- Automobile security system
- Home automation and security system

4. Pin Definition:

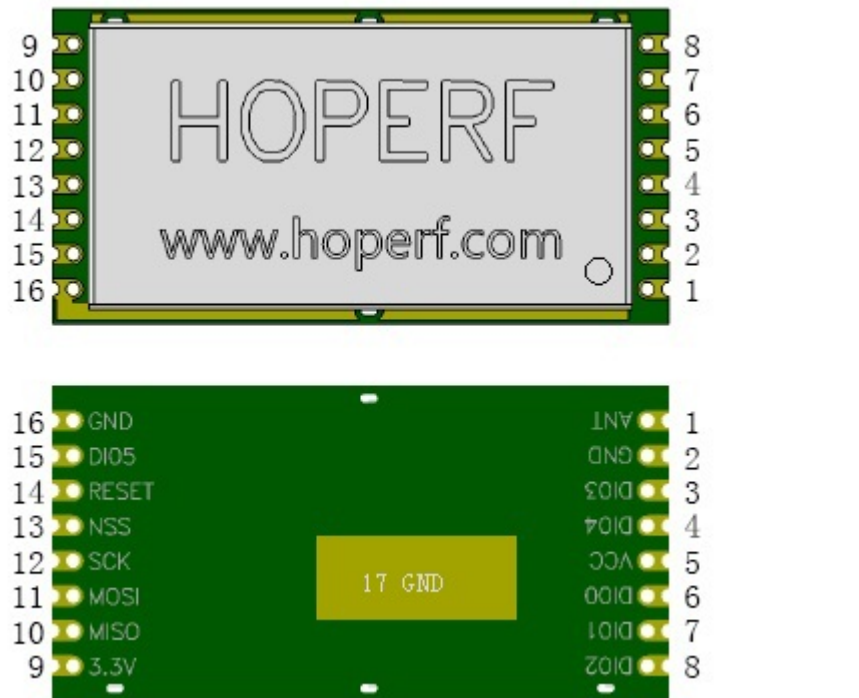

Figure 1. RFM98P/RFM95P Pin Definition

Number	Definition	Type	Function
1	ANT	AI/ AO	RF signal input/output.
2	GND	G	Power ground.
3	DIO3	I/O	Digital I/O, software configured.
4	DIO4	I/O	Digital I/O, software configured.
5	VCC	PI	Positive power supply, 5.0-6.4V.
6	DIO0	I/O	Digital I/O, software configured.
7	DIO1/DCLK	I/O	Digital I/O, software configured.
8	DIO2/DATA	I/O	Digital I/O, software configured.
9	3.3V	O	3.3V Voltage output. For MCU VCC.
10	MISO	O	SPI Data output.
11	MOSI	I	SPI Data input.
12	SCK	I	SPI Clock input.
13	NSS	I	SPI Chip select input.
14	RESET	I/O	Reset trigger input.
15	DIO5	I/O	Digital I/O, software configured.
16	GND	G	Power ground.
17	GND	G	Power ground ,This area is connected to the GND network of the main board for heat radiation.

5. Typical Application:

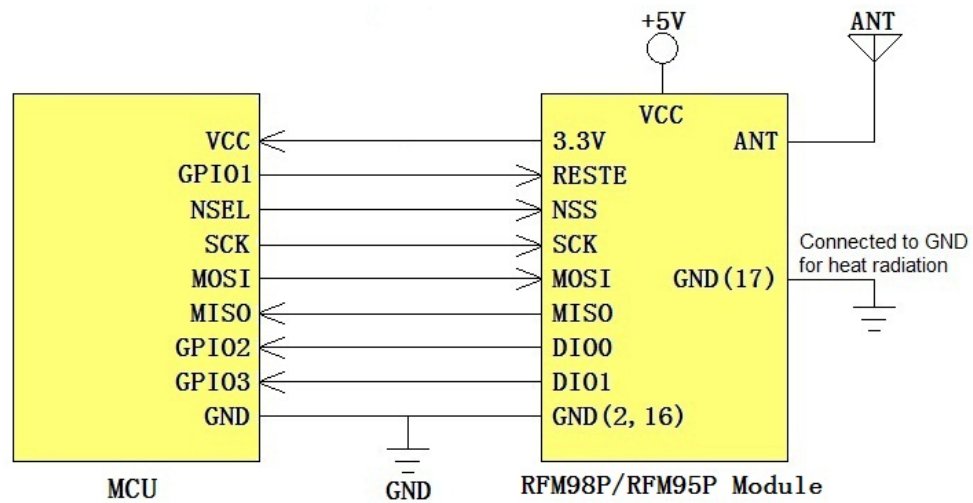

Figure 2. RFM98P/RFM95P Application

(For software info please refer to RF98/RF96 chip datasheets and demo program of HopeDuino™ Development Kit)

6. Electrical Parameter:

Maximum

parameter	minimum	maximum	Unit
Positive power supply	-0.3	+6	V
Voltage on Digital Control Inputs	-0.3	3.3 + 0.3	V
Voltage on Analog Inputs	-0.3	3.3 + 0.3	V
RX Input Power	-	+10	dBm
Storage temperature	-55	+125	°C
Soldering temperature(10s)	-	+260	°C

Recommended working range

parameter	minimum	maximum	Unit
Positive power supply	+5.0	+6.0	V
Working temperature	-20	+70	°C

DC characteristic

parameter	conditions	minimum	typical	maximum	Unit
TX Working current	169MHz band, P _{out} =+27dBm	-	400	600	mA
	433MHz band, P _{out} =+30dBm	-	650	900	
	470MHz band, P _{out} =+30dBm	-	650	900	
	868MHz band, P _{out} =+27dBm	-	650	900	
	915MHz band, P _{out} =+27dBm	-	650	900	
RX Working current	169MHz band,	-	13	15	mA
	433MHz band,	-	13	15	
	470MHz band,	-	13	15	
	868MHz band,	-	13	15	
	915MHz band,	-	13	15	
Sleep current	All band	-	5	12	uA

Transmitter AC characteristic

parameter	conditions	minimum	typical	maximum	Unit
TX frequency range	169 MHz band,	159	-	175	MHz
	433 MHz band,	410	-	450	
	470 MHz band,	450	-	490	
	868 MHz band,	862	-	888	
	915 MHz band,	895	-	935	
Bit rate, FSK Mode	Programmable	1.2	-	300	kbps
Bit rate, OOK Mode	Programmable	1.2	-	32.768	kbps
Bit rate, Long-Range Mode	From SF6, BW=500kHz to SF12, BW=125kHz	0.183	-	37.5	kbps
Frequency deviation, FSK	Programmable FDA + BR/2 ≤ 250 kHz	0.6	-	200	KHz
Frequency synthesizer step	FSTEP = FXOSC/219	-	61.0	-	Hz
Output Power	169/868/915MHz band	-	27	-	dBm
	433/470MHz band	-	30	-	

Receiver AC characteristic

parameter	conditions	minimum	typical	maximum	Unit
RX Frequency Range	169 MHz band,	159	-	175	MHz
	433 MHz band,	410	-	450	
	470 MHz band,	450	-	490	
	868 MHz band,	862	-	888	
	915 MHz band,	895	-	935	
RX Sensitivity FSK Mode	FDA = 35 kHz, BR = 0.6 kb/s, All band	-	-117	-	dBm
RX Sensitivity OOK Mode	BR = 4.8 kb/s, All band	-	-117	-	dBm
RX Sensitivity Long-Range Mode	SF12, BW=125kHz, All band	-	-136	-	dBm
Single Side channel filter BW	Programmable	2.7	-	250	kHz

7. Mechanical Dimension

(All units in mm)

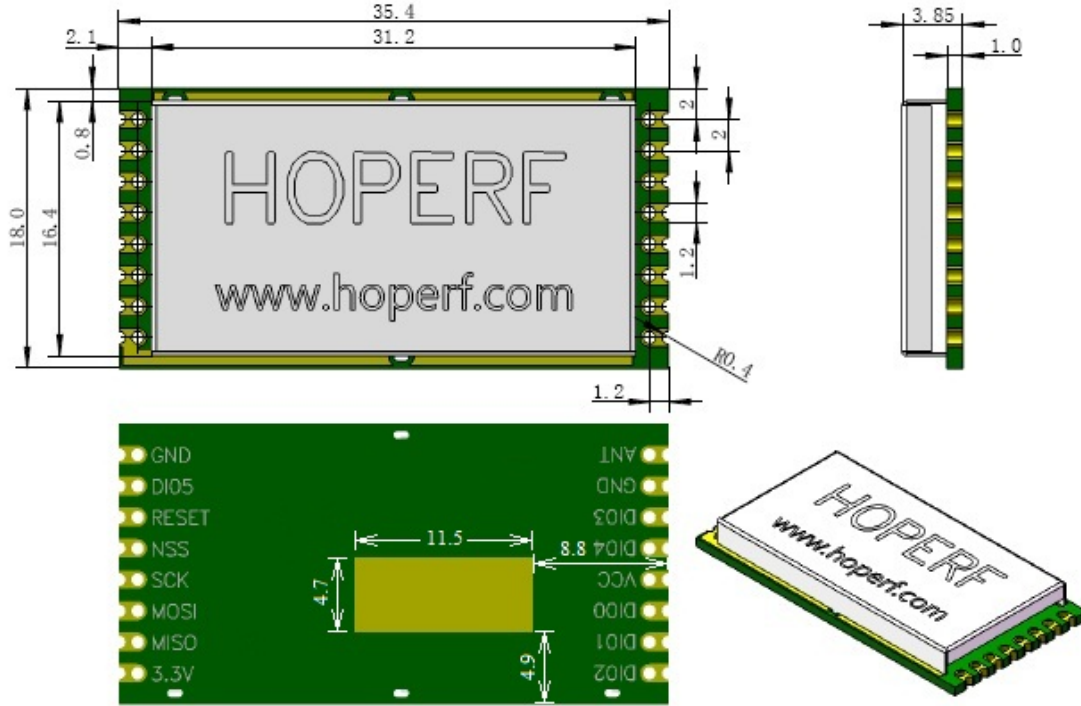

Figure3. RFM98P/RFM95P Mechanical Dimension

8. Order information

Model	Frequency band	Output power
RFM98P-169S2	169MHZ	27dBm
RFM98P-433S2	433MHZ	30dBm
RFM98P-470S2	470MHZ	30dBm
RFM95P-868S2	868MHZ	27dBm
RFM95P-915S2	915MHZ	27dBm

**Shenzhen Hope
Microelectronics Co., Ltd.**

Add: 30th floor of 8th Building, C Zone,
Vanke Cloud City, Xili Sub-district,
Nanshan, Shenzhen, GD, P.R. China

Tel: 86-755-82973805

Fax: 86-755-82973550

Email: sales@hoperf.com

Website: <http://www.hoperf.com>

This document may contain preliminary information and is subject to change by Hope Microelectronics without notice. Hope Microelectronics assumes no responsibility or liability for any use of the information contained herein. Nothing in this document shall operate as an express or implied license or indemnity under the intellectual property rights of Hope Microelectronics or third parties. The products described in this document are not intended for use in implantation or other direct life support applications where malfunction may result in the direct physical harm or injury to persons. NO WARRANTIES OF ANY KIND, INCLUDING, BUT NOT LIMITED TO, THE IMPLIED WARRANTIES OF MECHANABILITY OR FITNESS FOR A PARTICULAR PURPOSE, ARE OFFERED IN THIS DOCUMENT.

©2006, HOPE MICROELECTRONICS CO.,LTD. All rights reserved.