

2.0 – 5.5 V Low Power 315/433.92/868/915 MHz OOK Receiver

Features

- Operating frequency: 300 - 960 MHz
- OOK demodulation
- Data rate: 0.5 - 40 kbps
- Sensitivity: -109 dBm (3.0 kbps), 0.1%BER
- Receiver bandwidth: 330 kHz
- Image rejection ratio: 30 dB
- Maximum input signal: 10 dBm
- Run independently. Input from the antenna and output from data pin.
- No need for register configuration.
- Supply voltage options:
 - 3.0 – 5.5 V (High voltage mode)
 - 2.0 – 3.6 V (Low voltage mode)
- Low power consumption: 4.5 mA@ 433.92 MHz
- RoHS compliant

Description

CMT2210LH is a low power, high performance OOK RF receiver, suitable for wireless applications with 315 / 433.92 / 868 / 915 MHz and nearby frequency points in a ISM band. The CMT2210LH is a real plug and play chip. The CMT2210LH operates in a band of 300 - 960 MHz. The change of RF frequencies can be fulfilled by selecting crystals with different frequencies. The crystal frequencies corresponding to different RF frequencies can be read from the RFPDK interface. This chip is capable of a data rate range of 0.5 – 40 kbps and it is optimized to 1 - 5 kbps as factory setting, ideal for pairing with the low-cost transmitter based on the encoder or MCU. By selecting the VDD5V pin and VDDL pin open circuit or short circuit on the PCB, the CMT2210LH can operate in two voltage ranges, namely, 3.0 - 5.5 V and 2.0 - 3.6 V. When operating at 433.92MHz, the chip consumes only 4.5 mA current while achieving the receiver sensitivity of the -109 dBm. the CMT2210LH receiver, co-working with the CMT211x/5x receiver, can deliver cost-effective RF application solutions.

Applications

- Consumer electronics and appliances - lost-cost solution
- Home security and building automation
- Infrared receiver replacement
- Industrial monitoring and control
- Wireless metering reading
- Wireless lighting control system
- Wireless alarm and security system
- Remote Keyless Entry (RKE)

Ordering information

Product No.	Frequency	Packaging	MOQ
CMT2210LH-ESR	300 - 960 MHz	SOP8/Tape	3,000 pcs
See Section 6 for more order information details.			



SOP8

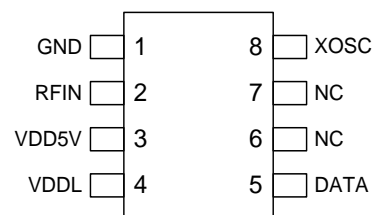

CMT2210LH PIN ARRANGEMENT DIAGRAM

Typical Applications

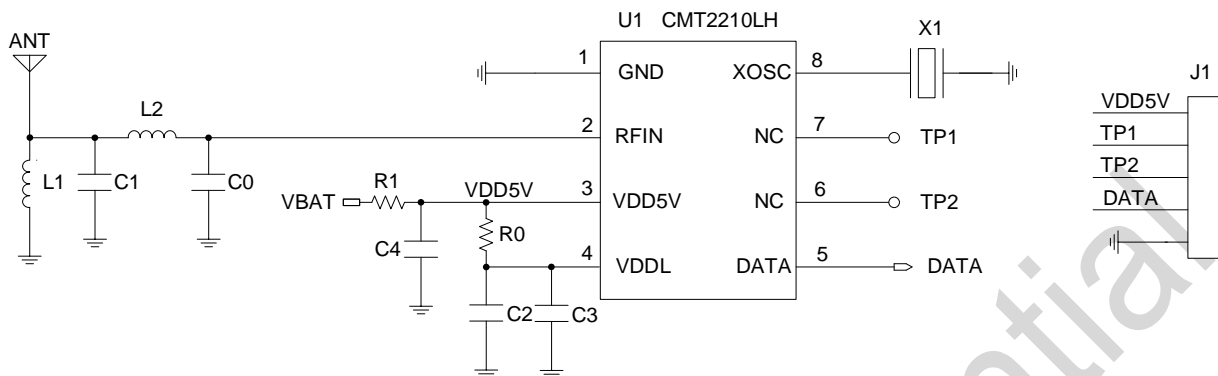

Figure 1. CMT2210LH Typical Application Schematic

Notes:

1. When selecting the 3.0 - 5.5 V operating voltage range, do not solder R0, namely, the connection between the VDD 5V pin and VDDL pin is broken.
2. When selecting the 2.0 - 3.6 V operating voltage range, R0 is 0, namely, the VDD 5V is shorted to the VDDL.
3. The purpose of connecting R1 to VDD-5V is to prevent the chip's power-up in a complex power environment, which achieves better chip protection.
4. J1 is programming pin. Suggest to keep it in product PCB.

Table 1. Typical Application BOM

Symbol	Description	Value (match to the $\lambda/4$ antenna)				Unit	Supplier
		315MHz	433.92MHz	868.35MHz	915MHz		
X1	± 20 ppm, SMD32*25 mm, crystal	26.2774	27.1412	26.3236	26.1522	MHz	EPSON
L1	$\pm 10\%$, 0603 stacked inductor	62	36	8.2	8.2	nH	Sunlord
L2	$\pm 10\%$, 0603 stacked inductor	68	36	12	10	nH	Sunlord
C0	± 0.25 pF, 0402 NP0, 50 V	3	3	-	-	pF	-
C1	± 0.25 pF, 0402 NP0, 50 V	12	10	7.5	7.5	pF	-
C2	$\pm 20\%$, 0603 X7R, 25 V	0.1				μ F	-
C3	$\pm 20\%$, 0603 NP0, 50 V	470				pF	-
C4	$\pm 20\%$, 0603 X7R, 25 V	0.1				μ F	-
R0	In 3-5.5V working environment, no welding is required; In 2-3.6V working environment, weld 0R.	0 / NC				Ω	-
R1	Protective resistor in series	4.7				Ω	
U1	CMT2210LH, 2.0 - 5.5 V power supply. 315/433.92/868/915 MHz OOK receiver.	-				-	CMOSTEK

Terminology

The terminologies used in this document are described in below.

AGC	Automatic Gain Control	PC	Personal computer
AN	Application note	PCB	Printed circuit board
BER	Bit Error Rate	PLL	Phase-locked loop
BOM	Bill of material	PN9	Pseudo-Random Binary Sequence
SC	Basic Spacing between Centers	POR	Power on reset
BW	Bandwidth	PUP	Power up
DC	Direct current	QFN	Quad Flat Non-lead
EEPROM	Electrically erasable programmable read-only memory	RF	Radio frequency
ESD	Electro-Static discharge	RFPDK	RF product development kit
SR	Equivalent series resistance	RoHS	Restriction of Hazardous Substances
IF	Intermediate frequency	RSSI	Received signal strength indicator
LNA	Low Noise Amplifier	Rx	Receiving, receiver
LO	Local oscillator	SAR	Successive approximation register
LPOSC	Low power oscillator	SOP	Small outline package
Max	Maximum	SPI	Serial Peripheral Interface
MCU	Micro controller unit	TH	Threshold
Min	Minimum	Tx	Transmitting, transmitter
MOQ	Minimum Order Quantity	Typ	Typical
NPO	Temperature compensation characteristic	VCO	Voltage controlled oscillator
NC	Not connected	XOSC	Crystal oscillator
OOK	On-off keying	XTAL/Xtal	Crystal

Table of Contents

1. Electrical Specifications	6
1.1 Recommended Operating Conditions	6
1.2 Absolute Maximum Rating	7
1.3 Receiver	8
1.4 Crystal Oscillator	9
2. Pin Description	10
3. Typical Performance	11
4. Typical Application Schematic	14
5. Function Description	16
5.1 Overview	16
5.2 Demodulation Mode, Frequency and Data Rate	17
5.3 Function Module Description.....	17
5.3.1 RF Front-end and Automatic Gain Control.....	17
5.3.2 Intermediate Frequency (IF) Filter.....	17
5.3.3 Received Signal Strength Indicator.....	17
5.3.4 Successive Approximation Register.....	17
5.3.5 Crystal Oscillator.....	18
5.3.6 Frequency Synthesizer	18
6. Ordering Information	19
7. Packaging Information	20
8. Top Marking	21
9. Reference Documents	22
10. Revise History	23
11. Contacts	24

1. Electrical Specifications

$V_{DD} = 3.3\text{ V}$, $T_{OP} = 25\text{ }^{\circ}\text{C}$, $F_{RF} = 433.92\text{ MHz}$, sensitivity is measured by receiving a PN9 sequence and matching to $50\text{ }\Omega$ impedance, 0.1% BER if nothing else stated. All measurement results are obtained using the evaluation board CMT221xLH-EM if nothing else stated.

1.1 Recommended Operating Conditions

Table 2. Recommended Operating Conditions

Parameter	Symbol	Condition	Min.	Typ.	Max.	Unit
Operating supply voltage	V_{DD}	VDD5V and VDDL are open, the temperature range is between $-40\text{ }^{\circ}\text{C}$ and $+85\text{ }^{\circ}\text{C}$.	3.0		5.5	V
		VDD5V and VDDL are shorted, the temperature range is between $-40\text{ }^{\circ}\text{C}$ and $+85\text{ }^{\circ}\text{C}$.	2.0		3.6	V
Operating temperature	T_{OP}		-40		85	$^{\circ}\text{C}$
Supply voltage slope			1			mV/us

1.2 Absolute Maximum Rating

Table 3. Absolute Maximum Rating^[1]

Parameter	Symbol	Condition	Min.	Max.	Unit
Supply voltage	V _{DD}	VDD5V and VDDL are not shorted	-0.3	5.5	V
		VDD5V and VDDL are shorted.	-0.3	3.6	V
Interface voltage	V _{IN}		-0.3	V _{DD} + 0.3	V
Junction temperature	T _J		-40	125	°C
Storage temperature	T _{STG}		-50	150	°C
Welding temperature	T _{SDR}	Last for at least 30 seconds		255	°C
ESD grade ^[2]		Human Body Model (HBM)	-2	2	kV
Latching current		@ 85 °C	-100	100	mA

Notes:

- [1]. Exceeding the *Absolute Maximum Ratings* may cause permanent damage to the equipment. This value is a pressure rating and does not imply that the function of the equipment is affected under this pressure condition, but if it is exposed to absolute maximum ratings for extended periods of time, it may affect equipment reliability.
- [2]. CMT2210LH is a high performance RF IC. The operation and assembly of this chip should only be performed on a workbench with good ESD protection.

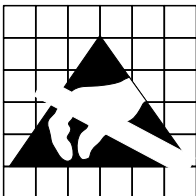

Warning! It is ESD sensitive device. In the operation of the chip, the user should pay attention to ESD precautions, so as to avoid the chip performance degradation or loss of function.

1.3 Receiver

Table 4. Receiver Specification

Parameter	Symbol	Condition	Min.	Typ.	Max.	Unit
Frequency range	F_{RF}	CMT2210LH	300		960	MHz
Data rate	DR		0.5		40	kbps
Sensitivity	S_{315}	$F_{RF} = 315$ MHz, DR = 3 kbps, BER = 0.1%		-109		dBm
	$S_{433.92}$	$F_{RF} = 433.92$ MHz, DR = 3 kbps, BER = 0.1%		-109		dBm
	$S_{868.35}$	$F_{RF} = 868.35$ MHz, DR = 3 kbps, BER = 0.1%		-108		dBm
	S_{915}	$F_{RF} = 915$ MHz, DR = 3 kbps, BER = 0.1%		-108		dBm
Input saturation level	P_{LVL}			10		dBm
Operating current	I_{DD315}	$F_{RF} = 315$ MHz		4.2		mA
	$I_{DD433.92}$	$F_{RF} = 433.92$ MHz		4.5		mA
	$I_{DD868.35}$	$F_{RF} = 868.35$ MHz		5.8		mA
	I_{DD915}	$F_{RF} = 915$ MHz		6.2		mA
Frequency synthesizer settling time	T_{LOCK}	Start from the stable crystal oscillation.		150		us
Block resistance;	BI	± 1 MHz, continuous wave interference		32		dB
		± 2 MHz, continuous wave interference		42		dB
		± 10 MHz, continuous wave interference		61		dB
Input 3rd order intercept point	IIP3	Dual tone test with frequency offset of 1 MHz and 2 MHz, at the maximum system gain setting		-23		dBm
Receiver bandwidth ^[1]	BW_{315}	$F_{RF} = 315$ MHz		240		kHz
	$BW_{433.92}$	$F_{RF} = 433.92$ MHz		330		kHz
	$BW_{868.35}$	$F_{RF} = 868.35$ MHz		240		kHz
	BW_{915}	$F_{RF} = 915$ MHz		240		kHz
Receiver startup time	$T_{START-UP}$	From power-up to receiving		$4.5 + T_{XTAL}^{[2]}$		ms

Notes:

[1]. The receiver supports 4 bandwidth options, namely 120 / 240 / 330 / 400 kHz. When the chip is operating at 433.92 MHz, the default receiving bandwidth is configured as 330 kHz, and the default receiving bandwidth for the other frequencies is 240 kHz. If necessary, users can select the required receiving bandwidth via RFPDK.

[2]. T_{XTAL} is the oscillation time of crystal, which is largely related to the crystal itself.

1.4 Crystal Oscillator

Table 5. Crystal Oscillator Specification

Parameter	Symbol	Condition	Min.	Typ.	Max.	Unit
Crystal frequency [1]	$F_{XTAL315}$	$F_{RF} = 315 \text{ MHz}$		26.2774		MHz
	$F_{XTAL433.92}$	$F_{RF} = 433.92 \text{ MHz}$		27.1412		MHz
	$F_{XTAL868.35}$	$F_{RF} = 868.35 \text{ MHz}$		26.3236		MHz
	$F_{XTAL915}$	$F_{RF} = 915 \text{ MHz}$		26.1522		MHz
Crystal frequency accuracy [2]				± 20		ppm
Load capacitor[3]	C_{LOAD}	SMD32*25 mm packaging		15		pF
		49USSMDor 49S packaging		22		pF
Crystal equivalent resistance	R_m				60	Ω
Crystal start-up time [4]	T_{XTAL}			400		us

Notes:

- [1]. The CMT2210LH can use the external reference clock to drive the XOSC pin through the coupling capacitor. The peak value of the external clock signal is between 0.3 and 0.7 V.
- [2]. The value includes (1) initial error (2) crystal load (3) aging and (4) frequency change with temperature. The acceptable crystal frequency error is limited by the receiver's bandwidth and the RF frequency deviation between the transmitter and the receiver.
- [3]. Due to the difference in parasitic capacitance caused by different crystal packaging, it is recommended to select crystals with different load capacitance values depending on the package used.
- [4]. The parameter is largely related to the crystal.

2. Pin Description

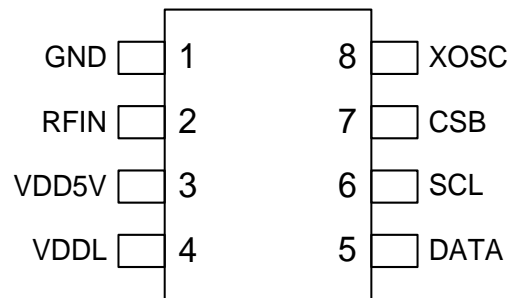

Figure 2. CMT2210LH Pin Arrangement

Table 6. CMT2210LH Pin Description

Pin #	Name	I/O	Function Description
1	GND	I	GND
2	RFIN	I	The RF signal is input to the LNA
3	VDD5V	I	Power input
4	VDDL	O	Power output
5	DATA	O	The programming DATA pin and received signal output pin. Suggest keep this programming point.
6	SCL	I	The programming SCL pin. Suggest keep this programming point.
7	CSB	I	The programming CSB pin. Suggest keep this programming point.
8	XOSC	I	Crystal oscillator input, or external reference clock input

3. Typical Performance

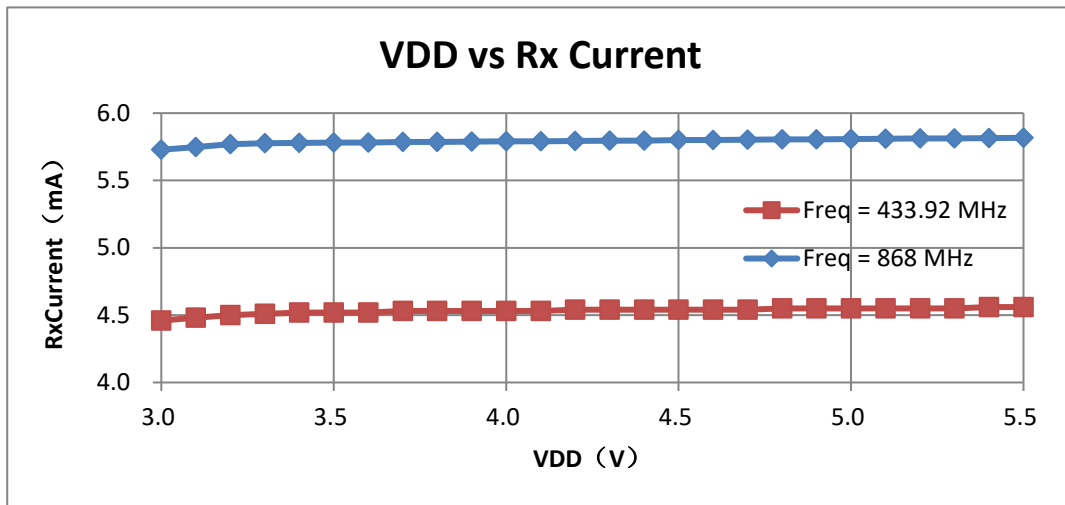

Figure 3. Rx Current vs. Supply Voltage

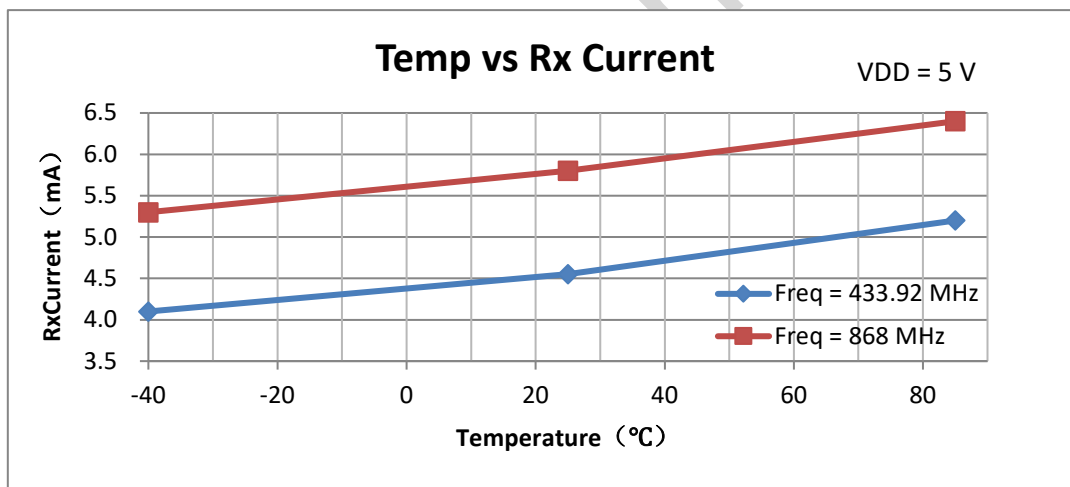

Figure 4. Rx Current vs. Operating Temperature

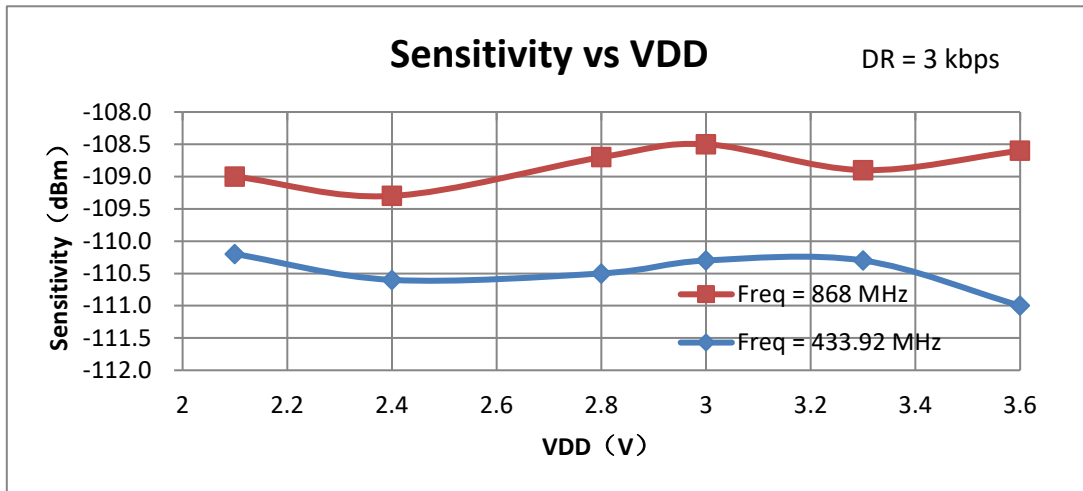

Figure 5. Sensitivity vs. Supply Voltage

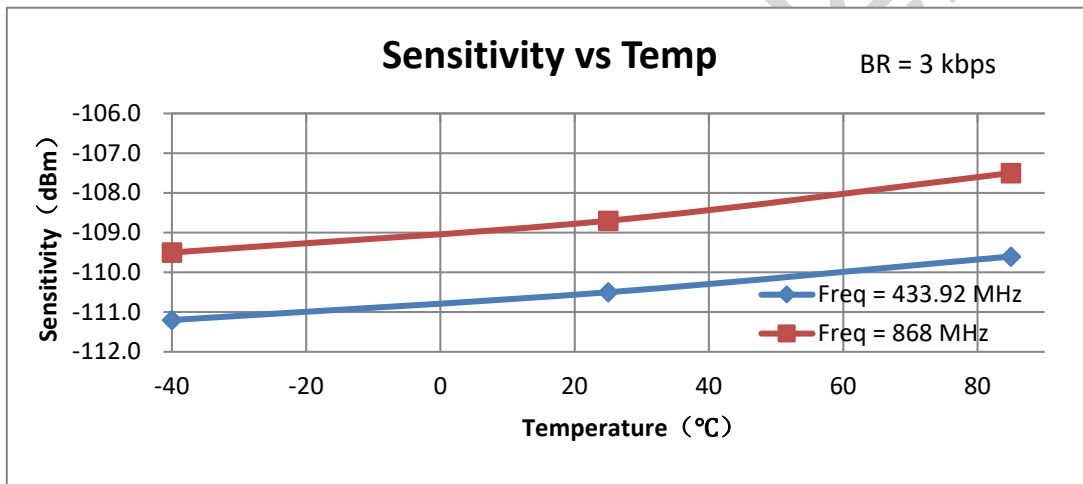

Figure 6. Sensitivity vs. Operating Temperature

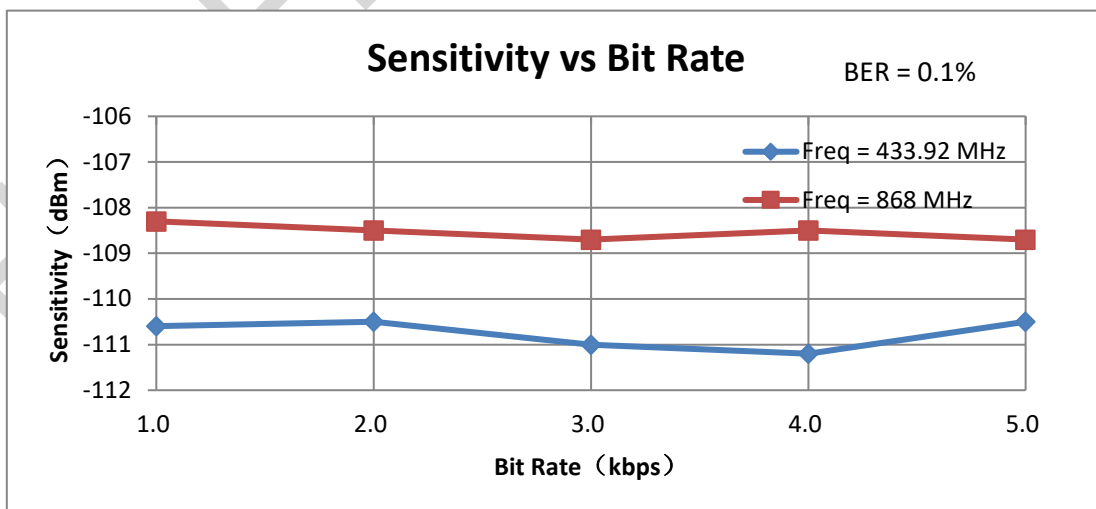

Figure 7. Sensitivity vs. Bit Rate

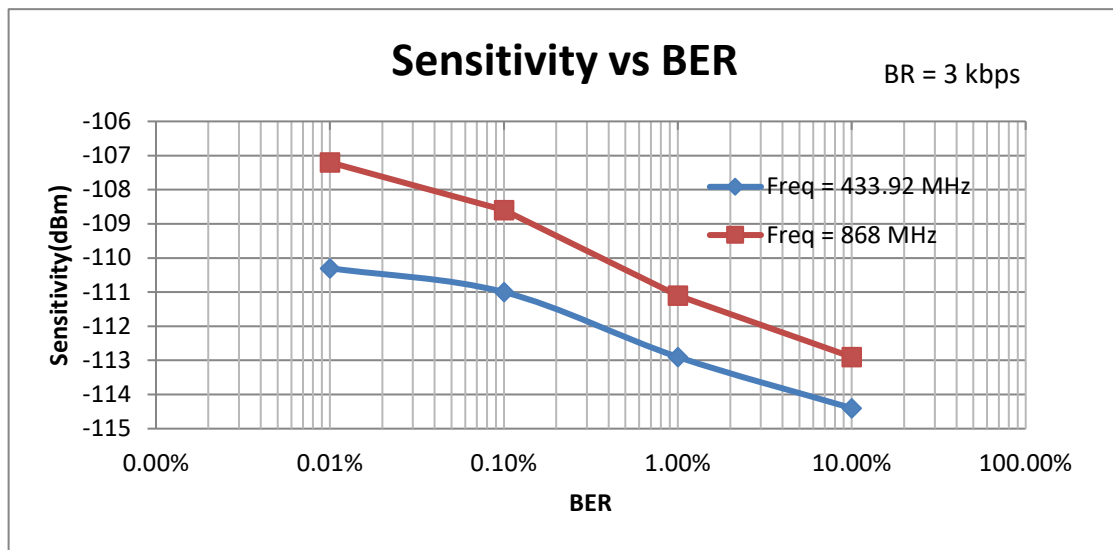

Figure 8. Sensitivity vs. Bit Error Rate

4. Typical Application Schematic

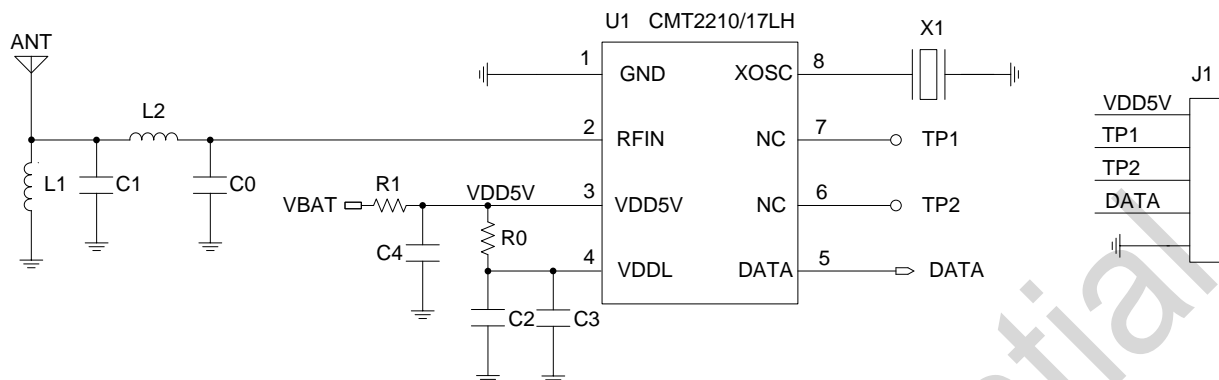

Figure 9. Typical Application Schematic Diagram

Notes:

1. The PCB layout rules are as below
 - Try to design the large and continuous ground.
 - Place L1, L2, C0 and C1 as close as possible to the chip, to reduce the distribution parameters of LNA and its loop and prevent a long loop, which may introduce noise signals.
 - Place crystal X1 as close as possible to the chip, so as to shorten the track between the crystal and the chip.
 - Place grounding vias along the edge of the plate as many as possible to reduce the radiation of the RF signal and the interference from outside. The spacing of the vias should be much smaller than 1/10 wavelength (operating frequency).
 - Place C2, C3, and C4 near to chip to achieve better filtering results.
 - The metal case of the crystal should be grounded.
2. Please refer to *AN158 CMT221xLH schematic and the PCB layout Guidelines* for more details on the PCB design.

Table 7. Typical Application BOM Matching 315 / 433.92 MHz

Symbol	Description	Value(Match to the $\lambda/4$ antenna)				Unit	Supplier
		315MHz	433.92MHz	868.35MHz	915MHz		
X1	± 20 ppm, SMD32*25 mm, crystal	26.2774	27.1412	26.3236	26.1522	MHz	EPSON
L1	$\pm 10\%$, 0603 stacked inductor	62	36	8.2	8.2	nH	Sunlord
L2	$\pm 10\%$, 0603 stacked inductor	68	36	12	10	nH	Sunlord
C0	± 0.25 pF, 0402 NP0, 50 V	3	3	-	-	pF	-
C1	± 0.25 pF, 0402 NP0, 50 V	12	10	7.5	7.5	pF	-
C2	$\pm 20\%$, 0603 X7R, 25 V	0.1				μ F	-
C3	$\pm 20\%$, 0603 NP0, 50 V	470				pF	-
C4	$\pm 20\%$, 0603 X7R, 25 V	0.1				μ F	-
R0	Not solder R0 for 3.0 - 5.0 V operating environment.	0 / NC				Ω	-
R1	Series protection resistor	4.7				Ω	
U1	CMT2210LH, 2.0 – 5.5 V power supply, 315/433.92/868/915 MHz OOK receiver.					-	CMOSTEK

5. Function Description

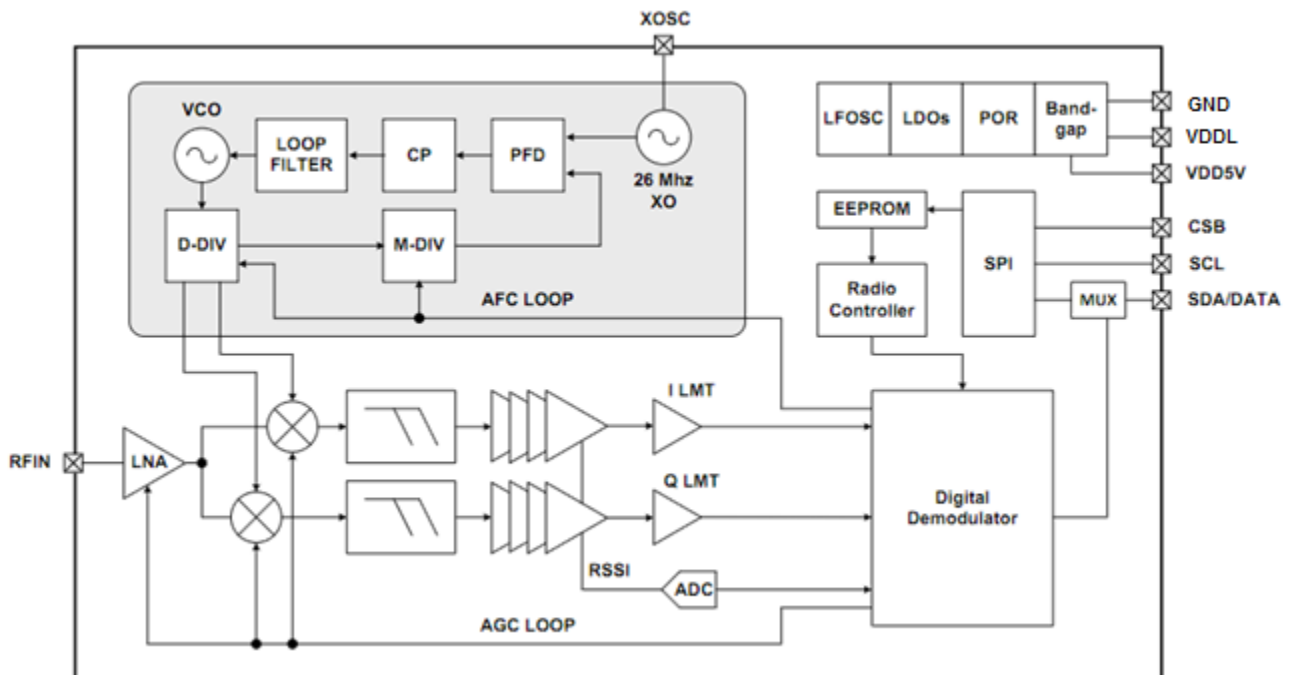

Figure 10. Function Module Diagram

5.1 Overview

The CMT2210LH is a digital-analog hybrid receiver. The product adopts the 26 MHz crystal to provide the reference frequency and digital clock for PLL, supports OOK demodulation output with a data rate of 0.5 - 40 kbps, and supports the periodic reset with the period time configurable, which can avoid chip crash caused by various external reasons. The CMT2210LH supports 2 operating voltages applicable for both 5V and 3V application systems.

The chip uses LNA+MIXER+IFFILTER+LIMITTER+PLL's low intermediate frequency structure to achieve the wireless reception function below Sub-1G frequency. The analog front-end is responsible for mixing RF signals into intermediate frequency, and converting the real time RSSI into the 8-bit digital signal through SAR-ADC, and sending them to the interior to perform the OOK demodulation and correlation processing. At the same time, the internal circuit will mix the intermediate frequency signal down to the zero frequency (baseband) and perform a series of filtering and judging process, while AGC dynamically controls the analog front-end. Finally, the original signal is demodulated and output through the DATA pin.

The parameters of the chip are stored in an internal EEPROM, and users can modify or adjust the operating parameters of the chip by the RFPDK.

5.2 Demodulation Mode, Frequency and Data Rate

CMT2210LH supports the OOK demodulation of 1.0 - 5.0 kbps data rate. The CMT2210LH supports 2 free ISM bands, 300 - 480 MHz and 600 - 960 MHz. The demodulation mode, frequency and data rate of the CMT2210LH is listed in the below table.

Table 9. Demodulation Mode, Frequency and Data Rate

Parameter	Value	Unit
Demodulation mode	OOK	-
CMT2210LH frequency range	300 – 480 600 - 960	MHz
Data rate	0.5 – 40	kbps

5.3 Function Module Description

5.3.1 RF Front-end and Automatic Gain Control

CMT2210LH is an OOK modulated receiver with a low intermediate frequency architecture. The receiver's RF front-end consists of a low-noise amplifier (LNA), an I / Q mixer (Mixer), an intermediate frequency filter (IF Filter), and a wideband power detector (WB Power Detector). The RF front-end amplifies and converts the RF input signals from the antenna to the intermediate frequency for further processing.

Through the broadband power detector and RF attenuation network of RF front-end, the automatic gain control (AGC) loop can adjust the RF front-end gain. The chip can also achieve optimal system linearity, selectivity and sensitivity even under the condition of strong interference outside the band.

By using a low-cost matching circuit, the LNA input can be matched to 50 Ω or other types of antennas.

5.3.2 Intermediate Frequency (IF) Filter

The signal from the RF front-end is filtered by an integrated 3rd order band pass image rejection filter. When the device operates at 433.92 MHz, the intermediate frequency bandwidth is 330 kHz. The center frequency and bandwidth will be adjusted automatically according to the selected crystal frequency.

5.3.3 Received Signal Strength Indicator

The output signal of the IF filter is amplified by the cascade I/Q logarithmic amplifier, and then sent to the demodulator for demodulation. I/Q dual logarithmic amplifiers include the received signal strength indicator (RSSI). The indicator generates the DC level in proportion to the input signal level within the I/Q path. The sum of levels of these two paths is used as an indication of the received signal strength, with a dynamic range of more than 66 dB.

5.3.4 Successive Approximation Register

The 8-bit SAR-ADC in CMT2210LH transforms the RSSI output into the digital signal for OOK demodulation.

5.3.5 Crystal Oscillator

The CMT2210LH uses a single-ended crystal oscillator circuit with the required load capacitance integrated within the chip. Recommend using crystals with an accuracy of + 20 ppm, an equivalent resistance (ESR) < 60 and a load capacitance (CLOAD) of 15pF.

If there is a suitable clock source in the application system, which can be used as the reference clock of CMT2210LH, users can drive the XOSC pin of the chip through the DC blocking capacitor. This will help save one crystal to further reduce the system cost. Recommend the clock source with a peak to peak value between 0.3 V to 0.7V (at the XOSC pin).

5.3.6 Frequency Synthesizer

The frequency synthesizer is used to generate the local oscillator (LO) frequency required for the I/Q mixer. Through the reference clock provided by a crystal or external clock source, the frequency synthesizer can generate the required operating frequencies. The internal high performance VCO operates at twice of the LO frequency. The chip can operate stably upon power-up with no need for external inductors.

HOPERF Confidential

6. Ordering Information

Table 10. CMT2210LH Ordering Information

Model	Description	Packaging	Package Option	Operating Condition	Minimum Order Quantity
CMT2210LH-ESR ^[1]	2.0 – 5.5 V Power supply, 300 - 960 MHz OOK receiver	SOP8	Tape & tray	2 – 3.6 V 3 – 5.5 V -40 – 85 °C	3,000

Notes:

[1]. "E" represents the extended industrial grade. The temperature range is from -40 to +85.

"S" represents the SOP8 packaging.

"R" represents the tape reel packing. MOQ is 3,000 pcs.

Please visit www.hoperf.com for more product information.

Please contact sales@hoperf.com or your local sales representative for sales or pricing requirements.

7. Packaging Information

The packaging information of the CMT2210LH is shown in the below figure.

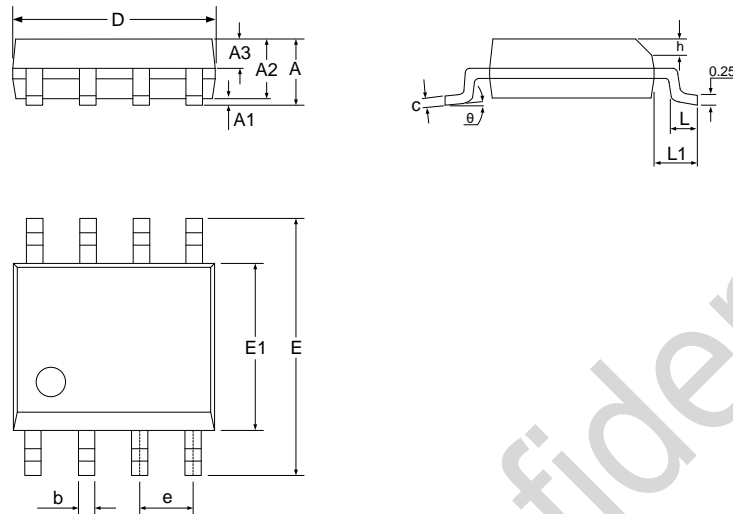

Figure 11. SOP8 Packaging

Table 11. SOP8 Packaging Scale

Symbol	Scale (mm)		
	Min.	Typ.	Max.
A	-	-	1.75
A1	0.10	-	0.225
A2	1.30	1.40	1.50
A3	0.60	0.65	0.70
b	0.39	-	0.48
c	0.21	-	0.26
D	4.70	4.90	5.10
E	5.80	6.00	6.20
E1	3.70	3.90	4.10
e	1.27 BSC		
h	0.25	-	0.50
L	0.50	-	0.80
L1	1.05 BSC		
θ	0	-	8°

8. Top Marking

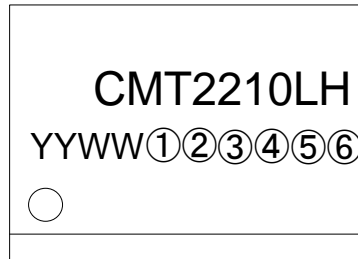

Figure 12. CMT2210LH Top Marking

Table12. CMT2210LH Top Marking Description

Marking method	Laser
Pin 1 mark	Circle diameter = 0.5 mm
Font height	0.6 mm, right aligned.
Font width	0.3 mm
Line 1 marking	CMT2210LH represents the model CMT2210LH
Line 2 marking	YYWW is the date code set by the packaging factory. YY represents the last 2 digits of the year. WW represents the manufacturing week. ①②③④⑤⑥ represents the internal tracking coding

9. Reference Documents

Table 13. CMT2210LH Related Documents

Doc No.	Name	Description
AN157	CMT221xLH Configuration Guideline	Introduce the configuring CMT2210LH and CMT2217LH details by RFPDK
AN158	CMT221xLH schematic and PCB layout guideline	Introduce CMT2210LH and CMT2217LH schematic and PCB layout design rules, RF matching network and other layout considerations.

HOPERF Confidential

10. Revise History

Table 14. Revise History Records

Version	Chapter	Modification descriptions	Date
0.1	All	Initial release version	2017-08-10
0.2	All	Fix spelling and grammar mistakes	2017-09-21
0.3	1	Page 2, Table 1, update supply voltage to 3.0 - 5.5 V	2018-02-07
0.5	All	Add chip model CMT2217LH and related information	2018-08-22
0.6	All	Add supporting full frequency band; Integrate all information into CMT2210LH and remove CMT2217LH information.	2021-12-14
0.7	All	Update the tube packing MOQ to 1000 and revise the frequency point data	2025-01-21
		P3 revise description in the column	2025/9/15
0.8	All	Remove the ESB-SOP8 tube packaging	2025/11/10

11. Contacts

Shenzhen Hope Microelectronics Co., Ltd.

Address: 30th floor of 8th Building, C Zone, Vanke Cloud City, Xili Sub-district, Nanshan, Shenzhen, GD, P.R. China

Tel: +86-755-82973805 / 4001-189-180

Fax: +86-755-82973550

Post Code: 518052

Sales: sales@hoperf.com

Website: www.hoperf.com

Copyright. Shenzhen Hope Microelectronics Co., Ltd. All rights are reserved.

The information furnished by HOPERF is believed to be accurate and reliable. However, no responsibility is assumed for inaccuracies and specifications within this document are subject to change without notice. The material contained herein is the exclusive property of HOPERF and shall not be distributed, reproduced, or disclosed in whole or in part without prior written permission of HOPERF. HOPERF products are not authorized for use as critical components in life support devices or systems without express written approval of HOPERF. The HOPERF logo is a registered trademark of Shenzhen Hope Microelectronics Co., Ltd. All other names are the property of their respective owners.