

EP-382 Micro Panel Printer User Manual



Draw up: ZhuChunyan 2018.04.08

Audit: HuRiYu 2018.04.10

Standardization: LiuZhonghua2018.04.11

Approved: WangHuanyong 2018.04.12

If there is any change in this specification and will not be further notice. Please kindly contact with Xiamen Cashino Electronic Technology Co., Ltd. for the the latest version.

Contents

1. Overview	5
2. Production featurer	5
3. External	5
3.1 External with lock	5
3.2 Cover Release Button External	7
3.3 Frame size diagram with lock	8
3.4 Cover release button structure size diagram	8
4. Technical parameters	9
5. Interface and define	10
6. Basic usage	11
6.1 Print self-test page	11
6.2 Panel LED Tips	11
6.3 Printer Cutter Test	12
6.4 The printer cutter resume work	12
6.5 Printer installation	13
7. Command Introduction	15
7.1 Command List	15
7.2 Commands details	16
① Printing and paper feed commands	16
Printing and paper feed	16
Enter	16
Print and paper feed n dots	17
Print and paper feed n dots	17
② Printing set commands	17
Set line space as n dots	17
Set line space to default	18
Set print position	18
Set the left margin	18
Set character printing method	19
Set character size	20
Set、 remove white printing	20
Set、 remove underline	21
Set、 remove 90° revolving printing	21
Set printing alignment	22
Set Chinese mode	22
Exit Chinese character mode	23
Select、 cancel user customized characters	23
Define user customized characters	23

Cancel user customized characters	25
Selecting international character set	26
Select character code	26
③Graphic printing command	28
Fill Graphics vertical module data	28
Print Graphics horizontal module data	29
Define downloaded bitmap	30
Define NV bitmap	32
Print NV bitmap	34
④Tab Commands	35
Horizontal tab	35
Horizontal tab position setting	36
⑤One-dimension bar code command	36
1D bar code readable character(HRI) print position setting	37
1D bar code height setting	37
1D bar code width setting	37
1D bar code printing	38
⑥Status querying Commands	43
Real-time transmission status	43
⑦Two-dimensional bar code commands	46
Mode type of QR code	46
Setting error correction level of QR code	47
Store QR code data to QR code data buffer	47
Printing QR code	48
Setting QR code graph information	48
Printing two dimensional code	49
⑧Printing double QR code	50
⑨Other commands	50
Printer reset	50
Print self-test page	51
Paper cut	51
Full cut	52
Partial cut	52
Specified pulse generation	52

1. Overview

EP-382 is 3inch kiosk thermal printer which is consist of thermal printer head ,cutter and control board. It is used for financial self-service terminals, communication self-service terminals, coupons self-service terminals, ticketing self-service terminals, power self-service terminals, medical self-service terminals, insurance self-service terminals,tax kiosks, self-service terminals such as kiosk terminal equipment, tanker, Queuing machines and so on.

2. Production featurer

- ※ Smart appearance
- ※ Easy paper loading
- ※ Low noise thermal printing
- ※ Different interfaces optional
- ※ Front panel make paper replacement easily
- ※ Support graphic and text printing
- ※ Support 80 mm diameter paper roll
- ※ Easily embedded to any kinds of instruments and meters

3. External

3.1 External with lock

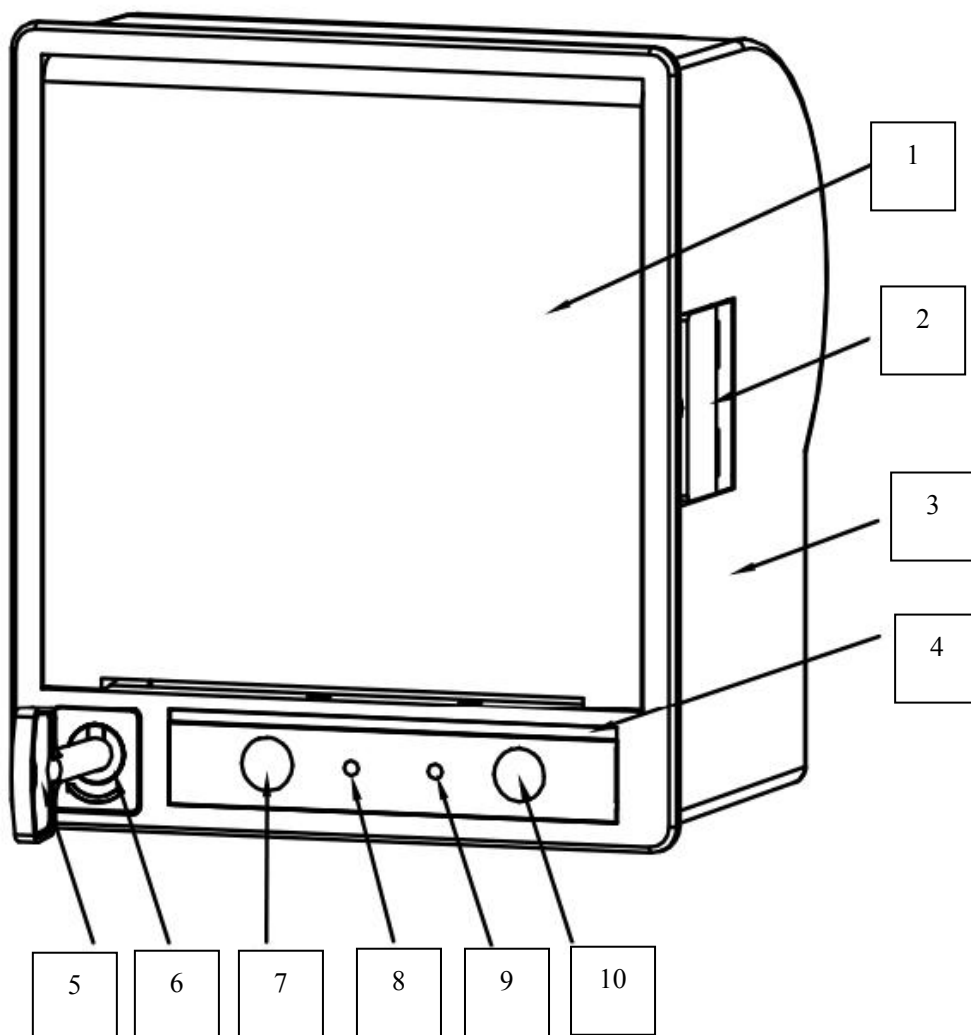

1. Printer Cover
2. Fixing Buckle
3. Bottom cover
4. Paper taken out detection and LED
5. Cover Release Button KEY
6. Cover Release Button
7. Power Switch
8. Status indicator
9. Power indicator
10. Feed button

3.2 Cover Release Button External

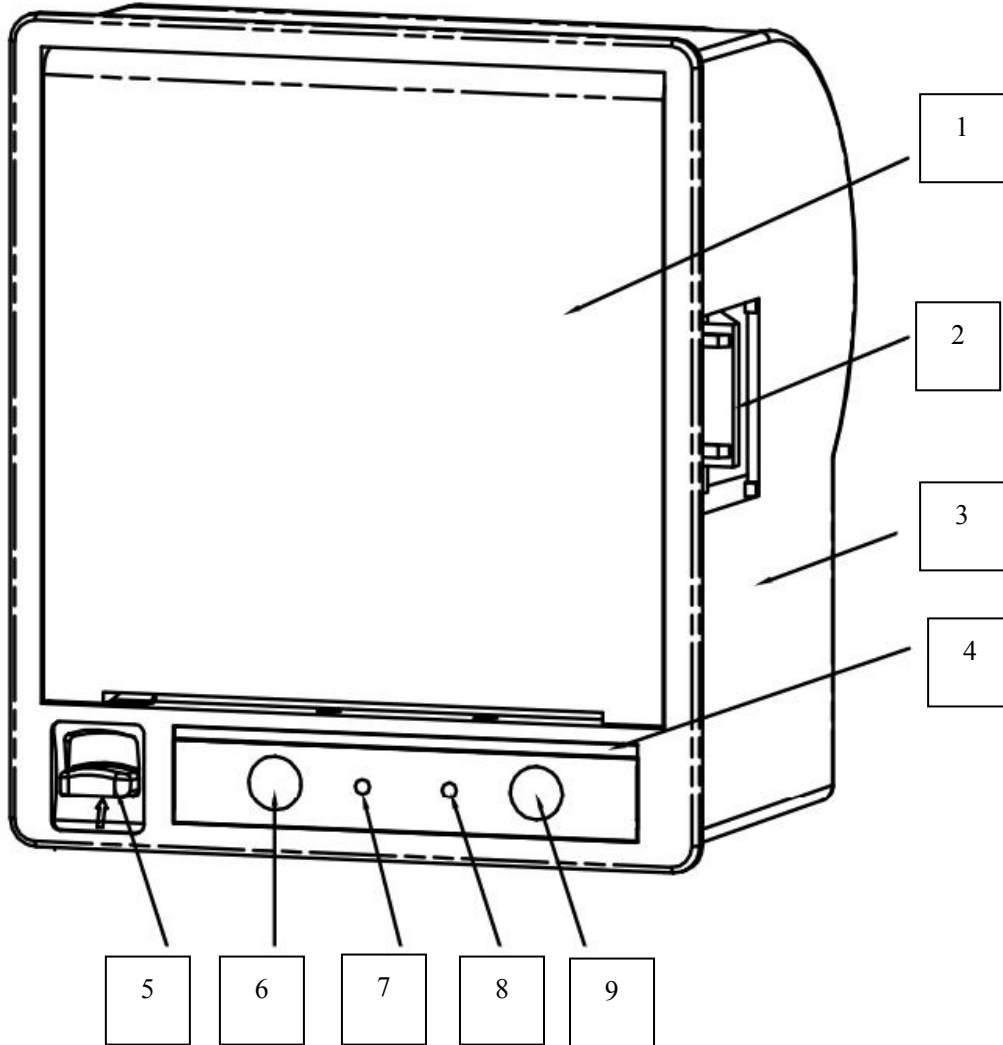

- 1. Printer Cover
- 2. Fixing Buckle
- 3. Bottom cover
- 4. Paper taken out detection and LED
- 5. Cover release button
- 6. Power Switch
- 7. Status indicator
- 8. Status indicator
- 9. Feed button

3.3 Frame size diagram with lock

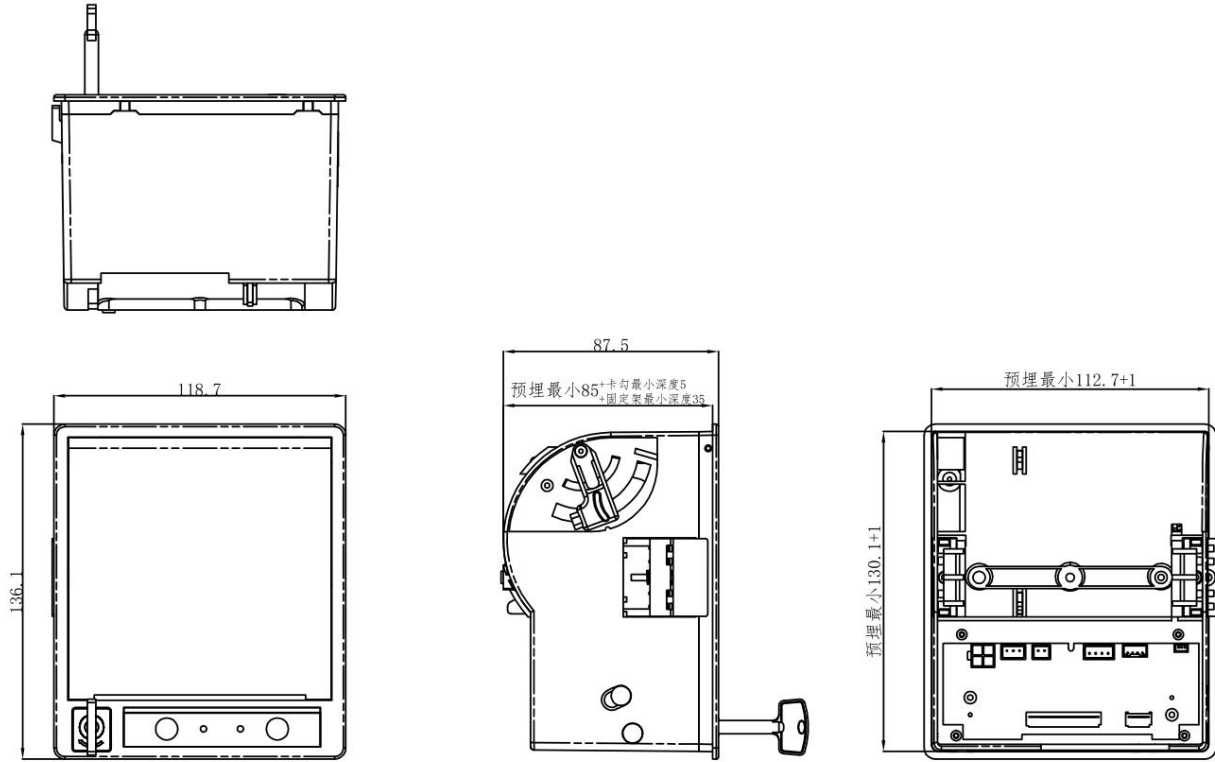

3.4 Cover release button structure size diagram

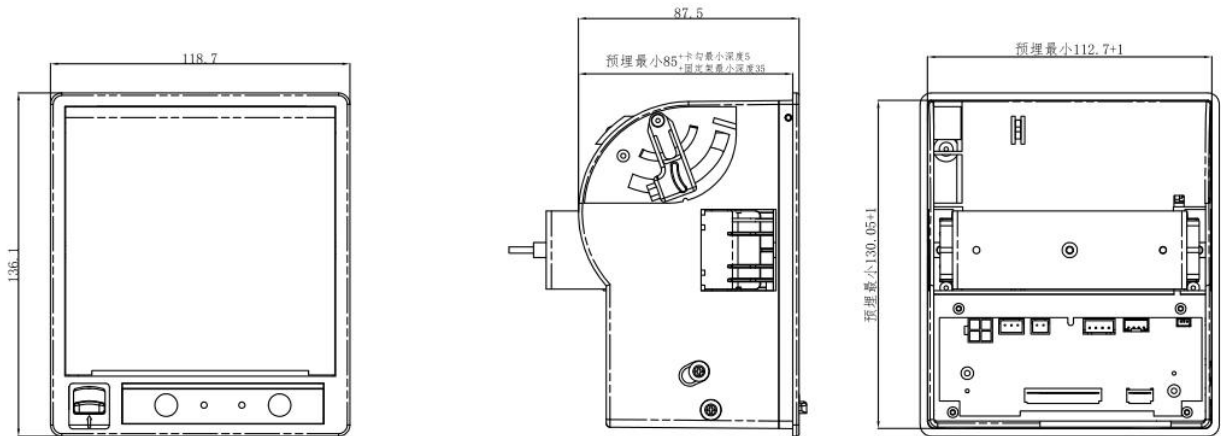

3.5 Push button structure size diagram

Example EP-382C K L W
 (1) (2) (3) (4)

(1)	Model Name	EP-380C
(2)	Default function	K=Printer with Key to open printer cover N=Printer with Button
(3)	Default function (Voltage)	L=12V H=24V
(4)	Default function (Printer Color)	W=White B=Black

4. Technical parameters

Model		EP-382_L	EP-382_H
Printing	Print method	Thermal-line dot method	
	Print speed	Max:150mm/s	Max:180mm/s
	Resolution	203dpi(8dots/mm)	
	Effective printing area	72mm	
Character	Character set	ASCII, GBK, BIG5 and so on	
	Character set	ANK: (9*17,12*24) Chinese: (24*24)	
	Print font	Font A (12*24) : 48 Font B (9*17) : 64 GBK: 24	
Paper Roll specification	Paper type	Thermal paper roll	
	Paper width	79.5±0.5mm	
	Paper thickness	0.055-0.09mm	
	Max paper roll diameter/paper roll inner diameter	Max:80mm;min:13mm	
detection	Head temperature detection	Thermistor	
	Paper out detection	Photoelectric detection	
	Paper near end detection	Photoelectric detection	
	paper taken out detection	Photoelectric detection+Flashing lights	
Baud rate		9600bps-115200bps	
Interface		Serial (RS232/TTL) , USB, Cash Drawer interface	

Barcode	1D code	UPC-A, UPC-E, JAN/EAN8, JAN/EAN13, CODE39, ITF, CODEBAR, CODE128, CODE93	
	2D code	QR code	
Reliability	Print Life	>100Km	
	Cutter life	>1000000cuts	
Cutter	Auto cutter	Support full cutter and half cutter simultaneously	
Power Supply		DC12V/4A Peak Current≥5A	DC 24V/2A Peak Current≥5A
Cash Drawer interface (options)		DC24V/1A	
Driver		Windows Driver, Linux Driver	
Environmental conditions	Operating temperature	0°C~50°C	
	Operating humidity	20%RH ~85% RH	
	Storage temperature	-20°C~60°C	
	Storage humidity	5% ~90%RH	
Physical	Outline dimension (wide * deep * high)	118.7*136.1*87.5mm	
	installation port size	130.7*113.3mm	
	Insert depth	>85mm	

5.Interface and define

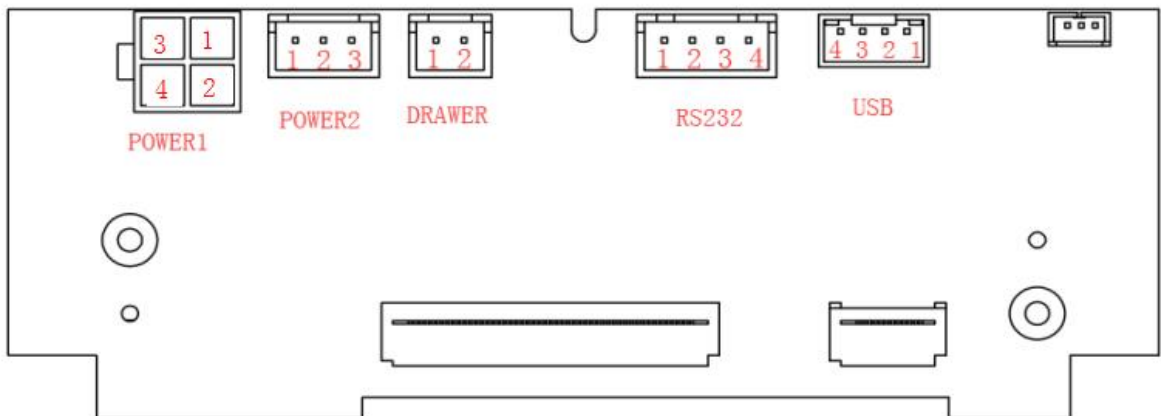

Power 1 Double row straight pin holder /XH4.2mm

No.	Pin	Introduction
1	GND	Signal ground
2	GND	Signal ground
3	VH	POWER
4	VH	POWER

Power2 XH2.54mm/3Pin

No.	Pin	Introduction
1	VH	POWER
2	NC	/
3	GND	Signal ground

Serial Port XH2.54mm/4Pin

No.	Pin	Introduction
1	DTR	Data terminal ready
2	TXD	Transmit data
3	RXD	Receive data
4	GND	Signal ground

Cash Drawer interface XH2.54mm/2Pin

No.	Pin	Introduction
1	VH	POWER
2	DRAWER	Cash Drawer control

6.Basic usage

6.1 Print self-test page

Method: under the shutdown state, hold down the FEED key, boot up, and print out a self-test page, which contains serial transmission rate, language and other Information.

6.2 Panel LED Tips

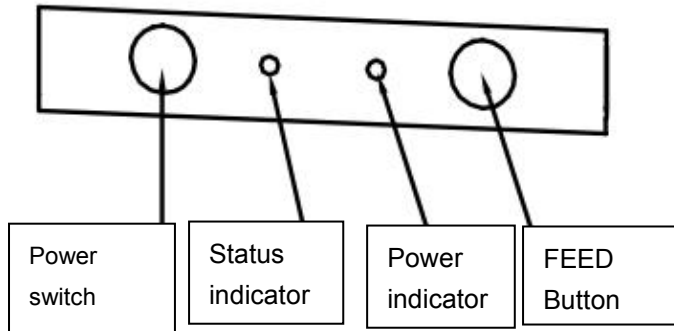

There are two indicators for the printer to remind the user of the STATUS of the printer, and the two indicators are POWER indicator and STATUS indicator respectively. There is also an unfilled LED light guide

POWER indicator(Blue)	STATUS indicator(Red)	Printer status
Keep bright	Light off	Working properly
Keep bright	Flash 2 times	Printer head is not connected or temperature is too low
Keep bright	Flash 3 times	Paper out
Keep bright	Flash 4 times	Cutter error
Keep bright	Flash 5 times	Printer head over heating
Keep bright	Flash 6 times	Platen open

6.3 Printer Cutter Test

When testing the cutter, it need more than a 3sec/cut to prevent the motor from burning down.

6.4 The printer cutter resume work

Owing to the paper jammed, if the cutter has been locked during paper cutting

Method one: Switch off the printer and turn the printer on again, and the cutter will return to its normal position.

Method Two: press the open-cover button several times and the cutter will return to its normal position.

6.5 Printer installation

Installation Method one: side installation

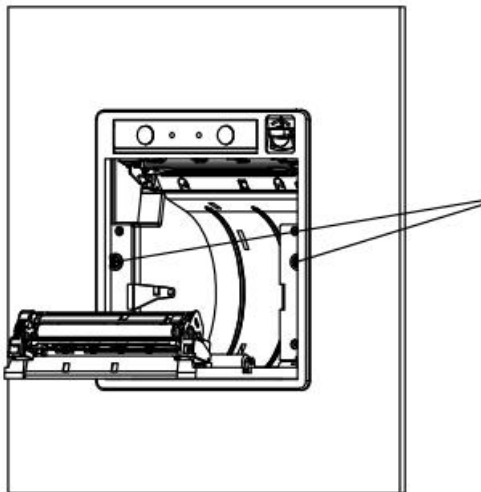
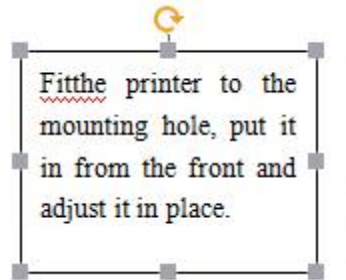
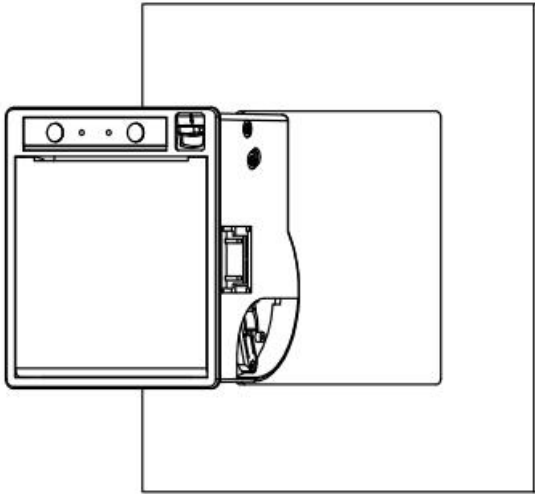

Open the top cover of the printer and turn the screws on the side clockwise until the screws are locked, so that the printer is fixed OK.

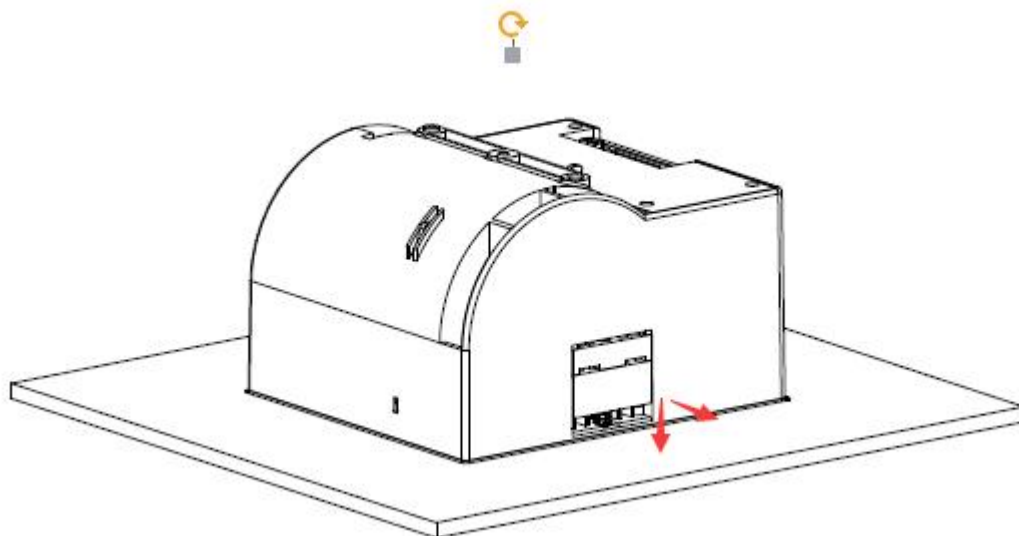

Fixing description: Turn the screw clockwise and the lock will move outward and upward until the panel is locked

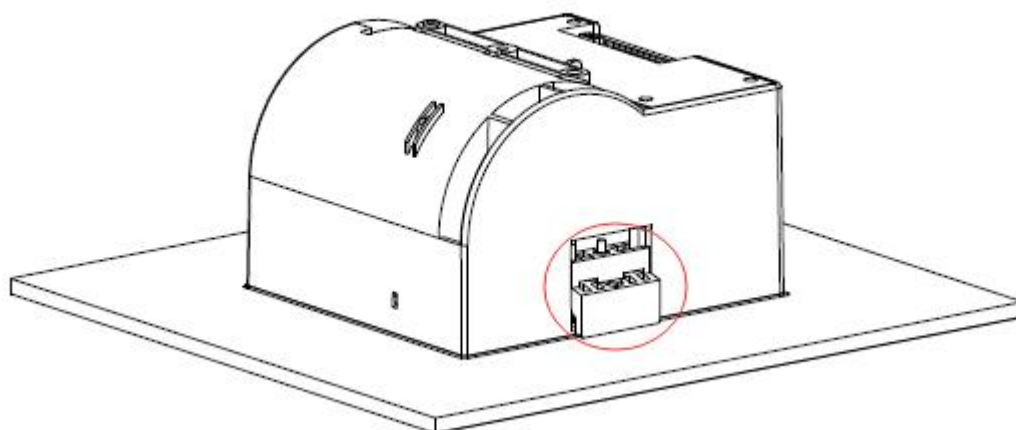

7. Command Introduction

7.1 Command List

LF	Line feed	Print, paper feed Command
CR	Enter	
ESC J	Print and paper feed n dots	
ESC d	Print and paper feed n lines	
ESC 3	Set line space as n dots	Printing-set Command
ESC 2	Set default line space	
ESC \$	Set printing position	
GS L nL nH	Set the amount of left margin	
ESC !	Set character printing method	
GS ! n	Set character printing method	
GS B n	Set, remove white printing	
ESC - n	Set, remove underline	
ESC V n	Set, remove 90°revolving printing	
ESC a	Setting position alignment mode	
FS &	Set Chinese character mode	
FS .	Cancel Chinese character mode	
ESC % n	Select , Cancel user customized character	
ESC &	Define user customized character	
ESC ? n	Cancel user customized character	
ESC R n	Select International character	
ESC t n	Select the character code page	
ESC *	Bitmap vertical modulus data fillings	Bitmap Command
GS v 0	Bitmap horizontal modulus data print	
GS *	Define Downstream bitma	
GS / m	Print Downstream bitmap	
FS q	Define NV bitmap	
FS p n m	Print NV bitmap	
HT	Horizontal tab	Tab Command
ESC D	Set horizontal tabulation position	
GS H	Set 1-D barcode readable	1-D barcode Command

	character(HRI) print position	
GS h	Set 1-D barcoe hight	
GS w	Set 1-D barcode width	
GS k	Print 1-D barcode	
GS (k	Print QR CODE	QR CODE Command
US Q m n	Print double QR CODE	
GS r n	Transmission status	Status Inquire Command
DLE EOT n	Real-time transmission status	
ESC @	Printer reset	Other Commands
DC2 T	Printing self-test page	
ESC i	Full cut	
ESC m	Partial cut	
ESC p	Cash drawer pulse	

7.2 Commands details

① Printing and paper feed commands

Printing and paper feed

Name	print and paper feed
Code	ASCII : LF DEC : 10 HEX : 0A
Function	Print the buffer contest,and set the paper feed as per line space,then adjust print position to initial position at the next line.
Range	None
Default	None
Notes	None
Example	None

Enter

Name	Enter
Code	ASCII : CR DEC : 13 HEX : 0D
Function	Adjust print position to initial position of the same line.
Range	None

Default	None
Notes	After executing, R command, the new printing data will cover old data in the printing buffer.
Example	None

Print and paper feed n dots

Name	Print and paper feed n dots
Code	ASCII : ESC J n DEC : 27 74 n HEX : 1B 4A n
Function	Print the buffer content and paper feed
Range	$0 \leq n \leq 255$
Default	None
Notes	Paper feed n dots when printing buffer is empty. After executing this command, printing position is moved to initial
Example	1b 40 30 31 32 1b 4a 10

Print and paper feed n dots

Name	Print and paper feed n dots
Code	ASCII : ESC J n DEC : 27 74 n HEX : 1B 4A n
Function	Print the buffer content and paper feed
Range	$0 \leq n \leq 255$
Default	None
Notes	Paper feed n dots when printing buffer is empty. After executing this command, printing position is moved to initial
Example	1b 40 30 31 32 1b 4a 10

② Printing set commands

Set line space as n dots

Name	Set line space as n dots
Code	ASCII : ESC 3 n DEC : 27 51 n HEX : 1B 33 n
Function	Set line space as n dots
Range	$0 \leq n \leq 255$
Default	n = 33
Notes	Line space as below: 

	<p>If the line space setted is less than the highest character in that line,then this line space is equal to the height of the highest character.</p> <p>If ESC2,ESC@,reset the printer, the printer blackout,and the line space turns to default.</p>
Example	<pre>1b 40 1b 33 30 30 31 32 0d 0a 30 31 32 0d 0a 1b 32 30 31 32 0d 0a 30 31 32 0d 0a</pre>

Set line space to default

Name	Set line space to default
Code	<p>ASCII : ESC 2</p> <p>DEC: 27 50</p> <p>HEX : 1B 32</p>
Function	Set line space to default 30 dots
Range	None
Default	None
Notes	<p>Line space in details pls check ESC 3 command.</p> <p>If the line space setted is less than the height character in the line,the line space of this line is equal to the height of the highest character</p> <p>It can use ESC 3 to define line space.</p>
Example	None

Set print position

Name	Set print position
Code	<p>ASCII : ESC \$ nL nH</p> <p>DEC : 27 36 nL nH</p> <p>HEX : 1B 24 nL nH</p>
Function	Set left side blank area as (nL + nH × 256) dots
Range	<p>0 ≤ nL ≤ 255</p> <p>0 ≤ nH ≤ 255</p>
Default	None
Notes	<p>Set left side blank area as[(nL+nH*256)]*0.125mm]</p> <p>This command is only effective with the initial position of the line.</p> <p>This command is unavailable if it sets beyond the printing area.</p>
Example	None

Set the left margin

Name	Set the left margin
Code	<p>ASCII : GS L nL nH</p> <p>DEC : 29 76 nL nH</p>

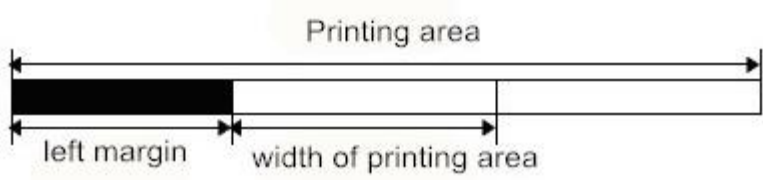
	HEX : 1D 4C nL nH
Function	Set the left margin as (nL + nH × 256) dots
Range	0 ≤ nL ≤ 255, 0 ≤ nH ≤ 255
Default	None
Support Model	All
Notes	<p>This command is only effective with the initial position of the line. The illustration is as follows:</p>  <p>Use the maximum value of the printable unit, if the setting is beyond the printable area.</p>
Example	<pre>1b 40 1d 4c 08 00 30 31 32 0d 0a 30 31 32 0d 0a</pre>

Set character printing method

Name	Set character printing method
Code	ASCII : ESC ! n DEC : 27 33 n HEX: 1B 21 n
Function	<p>Set character printing methods(font,highlight,inversion,bold,double height,double width and underline),parameter n bit definition as below:</p> <p>Bit Function Value</p> <p>0 1</p> <p>0 Font Normal Small character</p> <p>1 Undefined</p> <p>2 Undefined</p> <p>3Bold Cancel Setting</p> <p>4 Double height Cancel Setting</p> <p>5 Double width Cancel Setting</p> <p>6 Undefined</p> <p>7 Underline Cancel Setting</p>
Range	None
Default	n = 0
Notes	<p>The command is effective with Chinese and foreign languages. The command is disabled when ESC@, printer reset or power off</p>
Example	<pre>1B 40 1B 21 01 30 31 32 0D 0A 1B 40 1B 21 02 30 31 32 0D 0A 1B 40 1B 21 04 30 31 32 0D 0A 1B 40 1B 21 08 30 31 32 0D 0A 1B 40 1B 21 10 30 31 32 0D 0A</pre>

	1B 40 1B 21 20 30 31 32 0D 0A 1B 40 1B 21 40 30 31 32 0D 0A 1B 40 1B 21 80 30 31 32 0D 0A
--	---

Set character size

Name	Set character size																																																						
Code	ASCII : GS ! n DEC : 29 33 n HEX : 1d 21 n																																																						
Function	<p>Set character size as 1-8 times width,1-8 times height. Definition is as below: Use 0-3 set character height 4 - 7 bits set character width show as below:</p> <div style="display: flex; justify-content: space-around;"> <div style="text-align: center;"> <p>Chart 1</p> <p>Character width setting</p> <table border="1"> <thead> <tr> <th>HEX</th> <th>DEC</th> <th>width</th> </tr> </thead> <tbody> <tr><td>00</td><td>0</td><td>1(Normal)</td></tr> <tr><td>10</td><td>16</td><td>2(double width)</td></tr> <tr><td>20</td><td>32</td><td>3</td></tr> <tr><td>30</td><td>48</td><td>4</td></tr> <tr><td>40</td><td>64</td><td>5</td></tr> <tr><td>50</td><td>80</td><td>6</td></tr> <tr><td>60</td><td>96</td><td>7</td></tr> <tr><td>70</td><td>112</td><td>8</td></tr> </tbody> </table> </div> <div style="text-align: center;"> <p>Chart 2</p> <p>Character height setting</p> <table border="1"> <thead> <tr> <th>HEX</th> <th>DEC</th> <th>height</th> </tr> </thead> <tbody> <tr><td>00</td><td>0</td><td>1(Normal)</td></tr> <tr><td>01</td><td>1</td><td>2(double height)</td></tr> <tr><td>02</td><td>2</td><td>3</td></tr> <tr><td>03</td><td>3</td><td>4</td></tr> <tr><td>04</td><td>4</td><td>5</td></tr> <tr><td>05</td><td>5</td><td>6</td></tr> <tr><td>06</td><td>6</td><td>7</td></tr> <tr><td>07</td><td>7</td><td>8</td></tr> </tbody> </table> </div> </div>	HEX	DEC	width	00	0	1(Normal)	10	16	2(double width)	20	32	3	30	48	4	40	64	5	50	80	6	60	96	7	70	112	8	HEX	DEC	height	00	0	1(Normal)	01	1	2(double height)	02	2	3	03	3	4	04	4	5	05	5	6	06	6	7	07	7	8
HEX	DEC	width																																																					
00	0	1(Normal)																																																					
10	16	2(double width)																																																					
20	32	3																																																					
30	48	4																																																					
40	64	5																																																					
50	80	6																																																					
60	96	7																																																					
70	112	8																																																					
HEX	DEC	height																																																					
00	0	1(Normal)																																																					
01	1	2(double height)																																																					
02	2	3																																																					
03	3	4																																																					
04	4	5																																																					
05	5	6																																																					
06	6	7																																																					
07	7	8																																																					
Range	None																																																						
Default	n = 0																																																						
Notes	<p>This command is effective with Chinese and other foreign languages, except for HRI character. The command setting is disable when ESC@, printer reset or power off.</p>																																																						
Example	1b 40 1d 21 11 30 31 32 0d 0a 30 31 32 0d 0a																																																						

Set, remove white printing

Name	Set, remove white printing
Code	ASCII : GS B n DEC : 29 66 n HEX : 1d 42 n
Function	<p>Set and remove white printing When the LSB of n is 0,white printing mode is off. When the LSB of n is 1,white printing mode is on.</p>
Range	None
Default	n = 0
Notes	<p>It is only effective for LSB of n. This command is all effective with built-in characters and user-defined characters.</p>

	<p>It is effective with blank, which is set by ESC CP, when white printing mode is on. This command is not effective with bitmap, user-defined bitmap, barcode, HRI character and vaulting space of HT, ESC \$.</p> <p>This command is not effective with line space.</p> <p>The white printing mode is prior to underline mode. When it is white printing mode, even underline mode is open, which can also be forbidden. (But it not be canceled).</p> <p>This command is disabled when ESC@, printer reset or power off.</p>
Example	<pre>1b 40 1d 42 01 30 31 32 0d 0a 30 31 32 0d 0a</pre>

Set, remove underline

Name	Set, remove underline								
Code	<p>ASCII : ESC - n</p> <p>DEC : 27 45 n</p> <p>HEX : 1B 2D n</p>								
Function	<p>Set/ remove underline mode, based on the value of n as follow:</p> <table border="1" style="margin-left: 20px;"> <thead> <tr> <th>n</th> <th>Functions</th> </tr> </thead> <tbody> <tr> <td>0, 48</td> <td>Remove underline mode</td> </tr> <tr> <td>1, 49</td> <td>Set underline mode(1dotcoarse)</td> </tr> <tr> <td>2, 50</td> <td>Set underline mode(2dotcoarse)</td> </tr> </tbody> </table>	n	Functions	0, 48	Remove underline mode	1, 49	Set underline mode(1dotcoarse)	2, 50	Set underline mode(2dotcoarse)
n	Functions								
0, 48	Remove underline mode								
1, 49	Set underline mode(1dotcoarse)								
2, 50	Set underline mode(2dotcoarse)								
Range	$0 \leq n \leq 2, 48 \leq n \leq 50$								
Default	n = 0								
Notes	<p>Printer can print underline for all characters (including the space to the right of the character), except for the space set by HT.</p> <p>Printer can not print underline for clockwise rotated 90 ° characters and white printing characters.</p> <p>When n is set as 0 or 48, remove underline mode. Other data is not printed as underline, and the set underline coarseness does not change before removing underline mode. The default underline coarseness is 1 dot.</p> <p>It is not effective with underline coarseness to change character size.</p> <p>Using ESC! can also set and remove underline mode. However be aware that the last received command must be effective.</p>								
Example	<pre>1b 40 1b 2d 01 30 31 32 0d 0a 1b 40 1b 2d 02 30 31 32 0d 0a 1b 40 1b 2d 00 30 31 32 0d 0a</pre>								

Set, remove 90° revolving printing

Name	Set, remove 90° revolving printing
Code	<p>ASCII : ESC V n</p> <p>DEC : 27 86 n</p>

	HEX : 1B 56 n
Function	Set or remove 90°revolving printing When n is equal to 0 or 48,remove 90°revolving printing. When n is equal to 1 or 49,set 90°revolving printing.
Range	$0 \leq n \leq 1$, $48 \leq n \leq 49$
Default	n = 0
Support Model	All
Notes	When it is setted to underline mode, the printer is not underlined for characters rotated 90°. In the 90° rotation mode, the multiplier and double width commands magnify the character in the opposite direction to the multiplier command in the normal mode. When ESC @, printer reset, power off, the setting of this instruction is invalid.
Example	1b 40 1b 56 01 30 31 32 0d 0a 30 31 32 0d 0a

Set printing alignment

Name	Set print alignment (Left, middle, right)
Code	ASCII : ESC a n DEC : 27 97 n HEX : 1B 61 n
Function	Align all data in one line,the meaning of n value as below: n mode 0, 48 left 1, 49 middle 2, 50 right
Range	$0 \leq n \leq 2$ or $48 \leq n \leq 50$
Default	n = 0
Notes	This command setting is disabled when ESC@,printer resets or power off.
Example	1B 40 1B 61 02 30 31 32 0D 0A 1B 40 1B 61 01 30 31 32 0D 0A 1B 40 1B 61 00 30 31 32 0D 0A

Set Chinese mode

Name	Set Chinese mode
Code	ASCII : FS & DEC : 28 38 HEX: 1C 26
Function	Set Chinese mode

Range	None
Default	None
Notes	When the Chinese character mode is selected, the printer processes all Chinese character codes(ASCII code) , two bytes at a time. The Chinese character code(ASCII code) is processed in the order of the first byte and the second byte.
Example	1b 40 1C 26 B0 AE C9 CF D7 D4 BC BA 0d 0a 1C 2E B0 AE C9 CF D7 D4 BC BA 0d 0a

Exit Chinese character mode

Name	Exit Chinese character mode
Code	ASCII: FS . DEC : 28 46 HEX: 1C 2E
Function	Exit Chinese character mode, cancel Chinese character mode
Range	None
Default	None
Notes	None
Example	None

Select, cancel user customized characters

Name	Select 、 cancel user customized characters
Code	ASCII : ESC % n DEC : 27 37 n HEX : 1B 25 n
Function	Select 、 cancel user customized characters When n LSB is 0, delete customized characters When n LSB is 1, select customized characters
Range	$0 \leq n \leq 255$
Default	0
Notes	When cancel customized characters, automatically select the internal character set.
Example	None

Define user customized characters

Name	Define user customized characters
Code	ASCII : ESC & y c1 c2 [x1 d1 ... d (yx1)] ... [xk d1 ... d(y x k)] DEC : 27 38 y c1 c2 [x1 d1 ... d(yx1)] ...[xk d1 ... d(yxk)] HEX : 1B 26 y c1 c2 [x1 d1...d(y x1)]...[xk d1...d(yxk)]
Function	Define user customized characters. y specifies vertical direction bytes. c1 specifies the starting character encoding,c2 specifies the ending character encoding xk specifies horizontal direction dots.

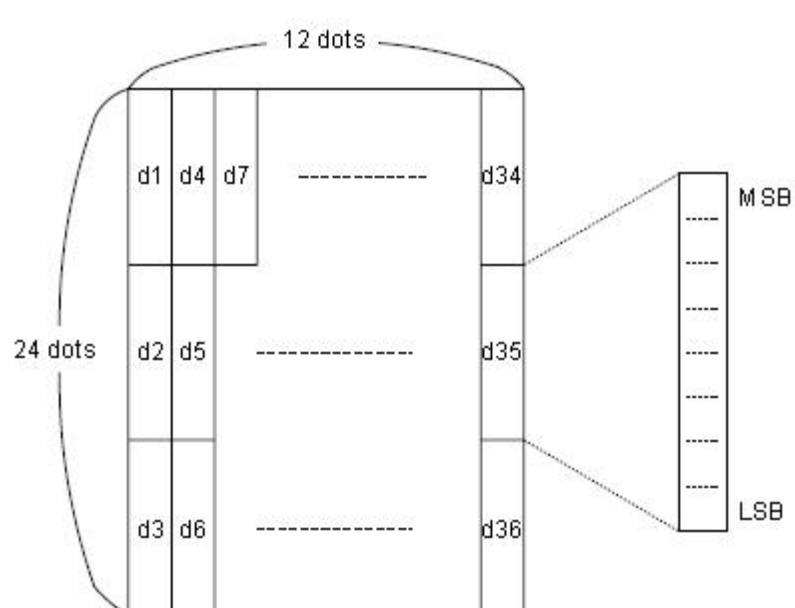
<p>Range</p>	<p>The range of x , y, are correspond with internal fonts. If choosing Font 6*12, y = 2, 0 ≤ x ≤ 6 If choosing Font 12*24, y= 3, 0 ≤ x ≤ 12 32 ≤ c1 ≤ c2 ≤ 126 0 ≤ d1 ... d(y*xk) ≤255</p>
<p>Default</p>	<p>None</p>
<p>Notes</p>	<p>Definable character code range:from<20>H to <7E>H ASCII code(95 characters). It can define continuous characters encoding for several characters.When it need one character only,make c1=c2. d is character's dot data,dot mode starts from left side in the horizontal direction.It is blank for the rest dots in the right side. Defined user defines characters data is (y*x) byte. Set corresponding bit of printing dots as 1, or corresponding bit of no printing dots as 0. This command defines different customized characters for each type of font. Set font with ESC !. Customized characters and down link bitmaps cannot be defined at the same time. When the command is executed, the down link bitmap is cleared. User Customized characters will be cleared in these situations: Execute ESC @。 Execute GS *。 Execute ESC ?。 Printer reset or power off</p> <p>Graphic: When set font A(12 24).</p> 

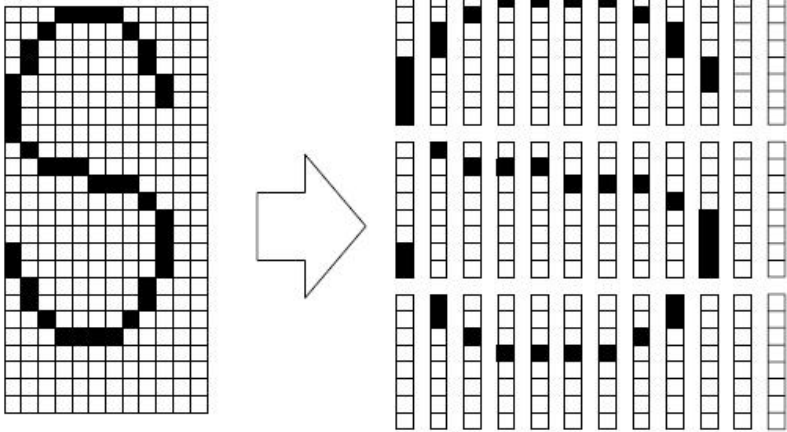
	 <p>d1= <0F>H d4 = <30>H d7 = <40>H d2 = <03>H d5 = <80>H d8 = <40>H d3 = <00>H d6 = <00>H d9 = <20>H</p>
Example	<p>①y = 2 1B 40 1b 26 02 20 20 06 FF FF FF FF FF FF FF FF FF FF FF 1b 25 01 20 20 0D 0A 1b 3f 20 30 20 30 20 0d 0a</p> <p>②y = 3 1B 40 1b 26 03 20 20 06 FF FF FF FF FF FF FF FF FF FF FF FF FF FF FF FF 1b 25 01 20 20 0D 0A 1b 3f 20 30 20 30 20 0d 0a</p>

Cancel user customized characters

Name	Cancel user customized characters
Code	ASCII : ESC ? n DEC : 27 63 n HEX : 1B 3F n
Function	Cancel user customized characters of specified code by n
Range	32 ≤ n ≤ 126
Default	None
Notes	This command terminates the use of styles defined for character encoding, which is specified by n. After the user customized character is canceled, it is printed in the corresponding mode of the internal character. In the font selected with ESC !, the command removes the style defined for the specified encoding. If a user customized character is not defined, the printer ignores the command.

Example	None
---------	------

Selecting international character set

Name	Selecting international character set																																		
Code	ASCII : ESC R n DEC : 27 82 n HEX: 1B 52 n																																		
Function	Selecting international character set n from the following table: <table style="margin-left: 40px;"> <tr> <td>n</td> <td>Character</td> </tr> <tr> <td>0</td> <td>U.S.A</td> </tr> <tr> <td>1</td> <td>France</td> </tr> <tr> <td>2</td> <td>Germany</td> </tr> <tr> <td>3</td> <td>U.K</td> </tr> <tr> <td>4</td> <td>Denmark I</td> </tr> <tr> <td>5</td> <td>Sweden</td> </tr> <tr> <td>6</td> <td>Italy</td> </tr> <tr> <td>7</td> <td>Spain I</td> </tr> <tr> <td>8</td> <td>Japan</td> </tr> <tr> <td>9</td> <td>Norway</td> </tr> <tr> <td>10</td> <td>Denmark II</td> </tr> <tr> <td>11</td> <td>Spain II</td> </tr> <tr> <td>12</td> <td>Latin America</td> </tr> <tr> <td>13</td> <td>Korea</td> </tr> <tr> <td>14</td> <td>Slovenia</td> </tr> <tr> <td>15</td> <td>China</td> </tr> </table>	n	Character	0	U.S.A	1	France	2	Germany	3	U.K	4	Denmark I	5	Sweden	6	Italy	7	Spain I	8	Japan	9	Norway	10	Denmark II	11	Spain II	12	Latin America	13	Korea	14	Slovenia	15	China
n	Character																																		
0	U.S.A																																		
1	France																																		
2	Germany																																		
3	U.K																																		
4	Denmark I																																		
5	Sweden																																		
6	Italy																																		
7	Spain I																																		
8	Japan																																		
9	Norway																																		
10	Denmark II																																		
11	Spain II																																		
12	Latin America																																		
13	Korea																																		
14	Slovenia																																		
15	China																																		
Range	$0 \leq n \leq 15$																																		
Default	0																																		
Notes	None																																		
Example	1B 40 1B 52 00 20 21 22 23 24 25 26 27 28 29 2A 2B 2C 2D 2E 2F 30 31 32 33 34 35 36 37 38 39 3A 3B 3C 3D 3E 3F 40 41 42 43 44 45 46 47 48 49 4A 4B 4C 4D 4E 4F 50 51 52 53 54 55 56 57 58 59 60 6A 6B 6C 6D 6E 6F 70 71 72 73 74 75 76 78 79 7A 7B 7C 7D 7E 0D 0A																																		

Select character code

Name	Select character code								
Code	ASCII : ESC t n DEC : 27 116 n HEX : 1B 74 n								
Function	Selects n from character code <table style="margin-left: 40px;"> <tr> <td>N</td> <td>Code Page</td> </tr> <tr> <td>0</td> <td>CP437[U.S.A., Standard Europe]</td> </tr> <tr> <td>1</td> <td>KataKana</td> </tr> <tr> <td>2</td> <td>CP850 [Multilingual]</td> </tr> </table>	N	Code Page	0	CP437[U.S.A., Standard Europe]	1	KataKana	2	CP850 [Multilingual]
N	Code Page								
0	CP437[U.S.A., Standard Europe]								
1	KataKana								
2	CP850 [Multilingual]								

3	CP860 [Portuguese]
4	CP863 [Canadian-French]
5	CP865 [Nordic]
6	WCP1251 [Cyrillic]
7	CP866 Cyrilliec #2
8	MIK [Cyrillic /Bulgarian]
9	CP755 [East Europe, Latvian 2]
10	Iran
11	Reserve
12	Reserve
13	Reserve
14	Reserve
15	CP862 [Hebrew]
16	WCP1252 Latin I
17	WCP1253 [Greek]
18	CP852 [Latina 2]
19	CP858 Multilingual Latin I +Euro)
20	Iran II
21	Latvian
22	CP864 [Arabic]
23	ISO-8859-1 [West Europe]
24	CP737 [Greek]
25	WCP1257 [Baltic]
26	Thai
27	CP720[Arabic]
28	CP855
29	CP857[Turkish]
30	WCP1250[Central Europe]
31	CP775
32	WCP1254[Turkish]
33	WCP1255[Hebrew]
34	WCP1256[Arabic]
35	WCP1258[Vietnam]
36	ISO-8859-2[Latin 2]
37	ISO-8859-3[Latin 3]
38	ISO-8859-4[Baltic]
39	ISO-8859-5[Cyrillic]
40	ISO-8859-6[Arabic]
41	ISO-8859-7[Greek]
42	ISO-8859-8[Hebrew]
43	ISO-8859-9[Turkish]
44	ISO-8859-15 [Latin 9]
45	Thai2
46	CP856
47	Cp874

	252 CP932 SHIFT_JIS 253 UNICODE UCS-2 254 BIG5 255 GBK
Range	$0 \leq n \leq 255$
Default	0
Notes	None
Example	1B 40 1C 2E 1B 74 00 80 81 82 83 84 85 86 87 88 89 8A 8B 8C 8D 8E 8F 90 91 92 93 94 95 96 97 98 9A 9B 9C 9D 9E 9F A0 A1 A2 A3 A4 A5 A6 A7 A8 A9 AA AB AC AD AE AF B0 B1 B2 B3 B4 B5 B6 B7 B8 B9 BA BB BC BD BE BF C0 C1 C2 C3 C4 C5 C6 C7 C8 C9 CA CB CC CD CE CF D0 D1 D2 D3 D4 D5 D6 D7 D8 D9 DA DB DC DD DE DF E0 E1 E2 E3 E4 E5 E6 E7 E8 E9 EA EB EC ED EE EF F0 F1 F2 F3 F4 F5 F6 F7 F8 F9 FA FB FC FD FE FF 0D 0A

③ Graphic printing command

Fill Graphics vertical module data

Name	Fill Graphics vertical module data
Code	ASCII : ESC * m HI Hh [d]k DEC : 27 42 m HI Hh [d]k HEX : 1B 2A m HI Hh [d]k
Function	Print vertical module graphic data,the parameters as below: m is bit map format: m mode horizontal scale vertical scale 0 8dots single density ×2 ×3 1 8dots double density ×1 ×3 32 24dots single density ×2 ×1 33 24dots double density ×1 ×1 HI、Hh is horizontal direction dots(HI+256×Hh) [d]k is bit map data K used for indicating bit map data bytes,not for transfer.
Parameter range	XX58: m=0、1、32、33 $1 \leq HI + Hh \times 256 \leq 384$ $0 \leq d \leq 255$ $k = HI + Hh \times 256$ (when m=0、1) $k = (HI + Hh \times 256) \times 3$ (when m=32、33) XX80: m=0、1、32、33 $1 \leq HI + Hh \times 256 \leq 576$ $0 \leq d \leq 255$ $k = HI + Hh \times 256$ (when m=0、1)

	$k=(Hl + Hh \times 256) \times 3$ (when $m=32、33$)
Default	None
Notes	<p>[d]k corresponding bit is 1, which means that this bit can print. While it is 0, it means that this bit can not print.</p> <p>The part of graphics horizontal direction which exceeds the printing area will be ignored.</p> <p>The relations between Bit map data and printing effects is as below:</p> <div style="text-align: center;"> </div> <p>The command fills only the printing buffer, graphics printing can start only after receiving the printing commands. Printing buffer will be cleared after graphic printing.</p> <p>If you need to print higher graphics, you can divide it into several sections which has 8 ($m = 0、1$) or 24 ($m = 32、33$) dots graphics to print.</p> <p>After filling graphic data, you can continue to fill other information to make graphic and other information print simultaneously.</p> <p>After filling bitmap, you can use ESC J ($n=24$) command to print, and also can use LF command to print. But using LF command will cause paper feeding (feeding paper according to the line space), and make graphic continuous between different lines. And can set line space as 0 to avoid feeding too much. (Dot matrix printer may drift when it starts, pls send data continuously if occurs line broken.)</p>
Example	<pre>1B 40 1b 2a 00 0C 00 FF FF FF FF FF FF FF FF FF FF FF 1B 33 00 0A</pre>

Print Graphics horizontal module data

Name	Print Graphics horizontal module data																
Code	ASCII : GS v 0 DEC : 29 118 48 m xL xH yL yH [d]k HEX : 1D 76 30 m xL xH yL yH [d]k																
Function	<p>Print horizontal module graphic data, the parameters as below:</p> <p>m as bitmap method:</p> <table style="margin-left: 40px;"> <thead> <tr> <th>m</th> <th>Model</th> <th>Horizontal scale</th> <th>Vertical scale</th> </tr> </thead> <tbody> <tr> <td>0,48</td> <td>Normal</td> <td>× 1</td> <td>× 1</td> </tr> <tr> <td>1,49</td> <td>Double-width</td> <td>× 2</td> <td>× 1</td> </tr> <tr> <td>2,50</td> <td>Double-height</td> <td>× 1</td> <td>× 2</td> </tr> </tbody> </table>	m	Model	Horizontal scale	Vertical scale	0,48	Normal	× 1	× 1	1,49	Double-width	× 2	× 1	2,50	Double-height	× 1	× 2
m	Model	Horizontal scale	Vertical scale														
0,48	Normal	× 1	× 1														
1,49	Double-width	× 2	× 1														
2,50	Double-height	× 1	× 2														

	<p>3,51 Quadruple × 2 × 2</p> <p>xL、xH were selected as the data bytes (xL+xH×256) in the horizontal direction for the bitmap.</p> <p>yL、yH were selected as the data bytes(yL+yH×256) in the vertical direction for the bitmap.</p> <p>[d]k for bitmap data</p> <p>k for bitmap data bytes, k used for indicating, not for transfer.</p>																				
Parameter range	<p>XX58:</p> <p>$0 \leq m \leq 3; 48 \leq m \leq 51$</p> <p>$1 \leq xL + xH \times 256 \leq 48$</p> <p>$0 \leq yL \leq 255, 0 \leq yH \leq 255$</p> <p>$0 \leq d \leq 255$</p> <p>$k = (Hl + Hh \times 256) \times (yL + yH \times 256)$</p> <p>XX80:</p> <p>$0 \leq m \leq 3; 48 \leq m \leq 51$</p> <p>$1 \leq xL + xH \times 256 \leq 72$</p> <p>$0 \leq yL \leq 255, 0 \leq yH \leq 255$</p> <p>$0 \leq d \leq 255$</p> <p>$k = (Hl + Hh \times 256) \times (yL + yH \times 256)$</p>																				
Default	None																				
Notes	<p>[d] k corresponding bit is 1, which means that this bit can print. While it is 0, it means that this bit can not print.</p> <p>If the horizontal bytes exceed printing area, then the exceeding part will be ignored. The paper feeds accordingly to the image size when this commanding is using, not influenced by the setting of ESC 2, ESC 3 line space.</p> <p>After this command, the printing coordinates will be reset to the left margin and the image content will be cleared.</p> <p>the relationship between bitmap data and the printing effect is as below:</p> <table border="1" style="margin-left: auto; margin-right: auto;"> <tr> <td>d1</td> <td>d2</td> <td>.....</td> <td>dx</td> </tr> <tr> <td>d(x+1)</td> <td>d(x+2)</td> <td>.....</td> <td>d(x×2)</td> </tr> <tr> <td> </td> <td> </td> <td>.....</td> <td> </td> </tr> <tr> <td>.....</td> <td>d(k-2)</td> <td>d(k-1)</td> <td>dk</td> </tr> <tr> <td>MSB</td> <td>LSB</td> <td>MSB</td> <td>LSB</td> </tr> </table> <p>This command has the printing function, data will be transferred while printing, no need to use the printing command again</p>	d1	d2	dx	d(x+1)	d(x+2)	d(x×2)			d(k-2)	d(k-1)	dk	MSB	LSB	MSB	LSB
d1	d2	dx																		
d(x+1)	d(x+2)	d(x×2)																		
																				
.....	d(k-2)	d(k-1)	dk																		
MSB	LSB	MSB	LSB																		
Example	<p>1B 40</p> <p>1d 76 30 00 03 00 09 00</p> <p>FF FF</p> <p>FF FF</p>																				

Define downloaded bitmap

Name	Define downloaded bitmap
------	--------------------------

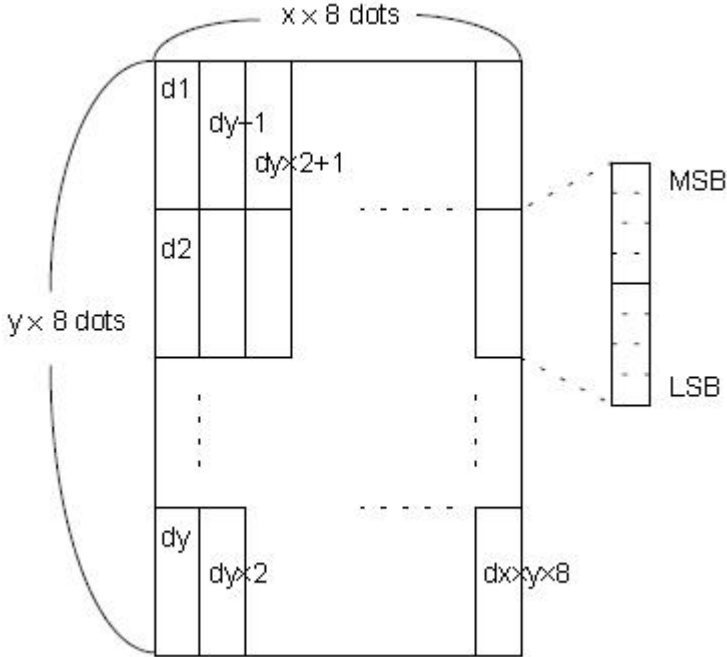
Code	ASCII : GS * x y d1...d(x*y*8) DEC : 29 42 x y d1 ...d(x*y*8) HEX : 1D 2A x y d1...d(x*y*8)
Function	using x and y to appoint dots to define the downloaded bitmap x appoints that the horizontal dots as 8*x. y appoints that the vertical dots as 8*y.
Parameter range	$1 \leq x \leq 255$ $1 \leq y \leq 48$ $x*y \leq 1536$ $0 \leq d \leq 255$
Default	None
Notes	<p>If $x*y$ is out of the specified range, this command will be forbidden.</p> <p>The d indicates bitmap data. Data (d) specifies the printing bit as 1 and the not printing bit as 0.</p> <p>The downloaded bitmap definition will be cleared when: ESC @ is executed. ESC & is executed. Printer is reset or the power is turned off.</p> <p>The following figure shows the relationship between the downloaded bitmap and the printed data</p>  <p>The diagram illustrates a grid of data points for a bitmap. The horizontal axis is labeled 'x × 8 dots' and the vertical axis is labeled 'y × 8 dots'. The data points are arranged in a grid with labels: d1, dy-1, dy*2+1, d2, dy, dy*2, and dx*y*8. A vertical stack of bits is shown to the right, with labels MSB (Most Significant Bit) and LSB (Least Significant Bit).</p>
Example	1B 40 1D 2A 03 03 FF 1D 2F 00

Define NV bitmap

Name	Define NV bitmap
Code	ASCII : FS q n [xL xH yL yH d1...dk]1...[xL xH yL yH d1...dk]n DEC : 28 113 n [xL xH yL yH d1...dk]1...[xL xH yL yH d1...dk]n HEX : 1C 71 n [xL xH yL yH d1...dk]1...[xL xH yL yH d1...dk]n
Function	Define the NV bitmap using the specified n. n specifies the number of the defined NV bitmap. xL, xH means that the defined NV bitmap specifies the horizontal dots as $(xL+xH*256)*8$ yL, yH means that the defined NV bitmap specifies the vertical dots as $(yL + yH*256)*8$
Parameter range	$1 \leq n \leq 255$ $0 \leq xL \leq 255$ $0 \leq xH \leq 3$ $(1 \leq (xL+xH*256) \leq 1023)$ $0 \leq yL \leq 255$ $0 \leq yH \leq 1$ $(1 \leq (yL+yH*256) \leq 288)$ $0 \leq d \leq 255$ $k = (xL+xH*256)*(yL+yH*256)*8$ Totalled the defined data Area = 64 k bytes
Default	None
Support Model	All
Notes	<p>Frequent writing command executions may damage the NV memory. Therefore, it is recommended to write the NV memory no more than 10 times per day.</p> <p>The printer performs a hardware reset operation after the procedure of placing the image into the NV memory. Therefore, user-defined characters, downloaded bitmaps should be defined only after completing this command. The printer clears the receiving and printing buffers and resets the printer to the mode that workable when power on. (hardware reset interface is not supported)</p> <p>This command cancels all NV bitmaps that have already been defined by this command.</p> <p>From the beginning of the processing of this command till the accomplishment of hardware reset, mechanical operations (including initializing the position of the print head when the cover is open, paper feeding using the FEED button, etc.) cannot be performed.</p> <p>During this command processing, the printer is busy and stops receiving data when writing data to the user's NV memory. Therefore, data transmission, including real-time commands, is prohibited during the execution of this command.</p> <p>NV bitmap is a bitmap defined in non-volatile memory, Define FS p printing</p>

with FS q.

In standard mode, this command is valid only when processed at the beginning of the line.

This command is valid when 7 bytes <FS yH> of the command are processed normally.

When the data volume exceeds the left capacity of the range defined by xL, xH, yL, and yH, the printer will process the range defined by xL, xH, yL, and yH outside the defined range.

In the first group of NV bitmaps, when any one of xL, xH, yL, yH is out of the definition range, this command is disabled.

In groups of NV bitmaps other than the first group, when xL, xH, yL, yH out of the defined range, it stops processing this command and starts writing into the NV images. At this time, NV bitmaps that haven't been defined are disabled (undefined), but any NV bitmaps before that are enabled.

The d indicates the definition data. In data (d) a 1 bit specifies a dot to be printed and a 0 bit specifies a dot not to be printed.

This command defines n as the number of a NV bitmap. Numbers rise in order from NV bitmap 01H. Therefore, the first data group [xL xH yL yH d1...dk] is NV bitmap 01H, and the last data group [xL xH yL yH d1...dk] is NV bitmap n. The total agrees with the number of NV bitmaps specified by the command FS p.

The definition data for an NV bitmap consists of [xL xH yL yH d1...dk]. Therefore, when only one NV bitmap is defined n=1, the printer processes a data group [xL xH yL yH d1...dk] once. The printer uses ([data: (xL xH × 256) × (yL yH × 256) × 8] [header :4]) bytes of NV memory.

The definition area in this printer is a maximum of 192K bytes. This command can define several NV bitmaps, but cannot define bitmap data whose total capacity [bitmap data header] exceeds 192K bytes.

The printer does not transmit ASB status or perform status detection during processing of this command even when ASB is specified.

Once an NV bitmap is defined, it is not erased by performing ESC @, reset, and power off.

This command performs only definition of an NV bitmap and does not perform printing. Printing of the NV bitmap is performed by the FS p command.

Diagram: when xL = 64, xH = 0, yL = 96, yH = 0

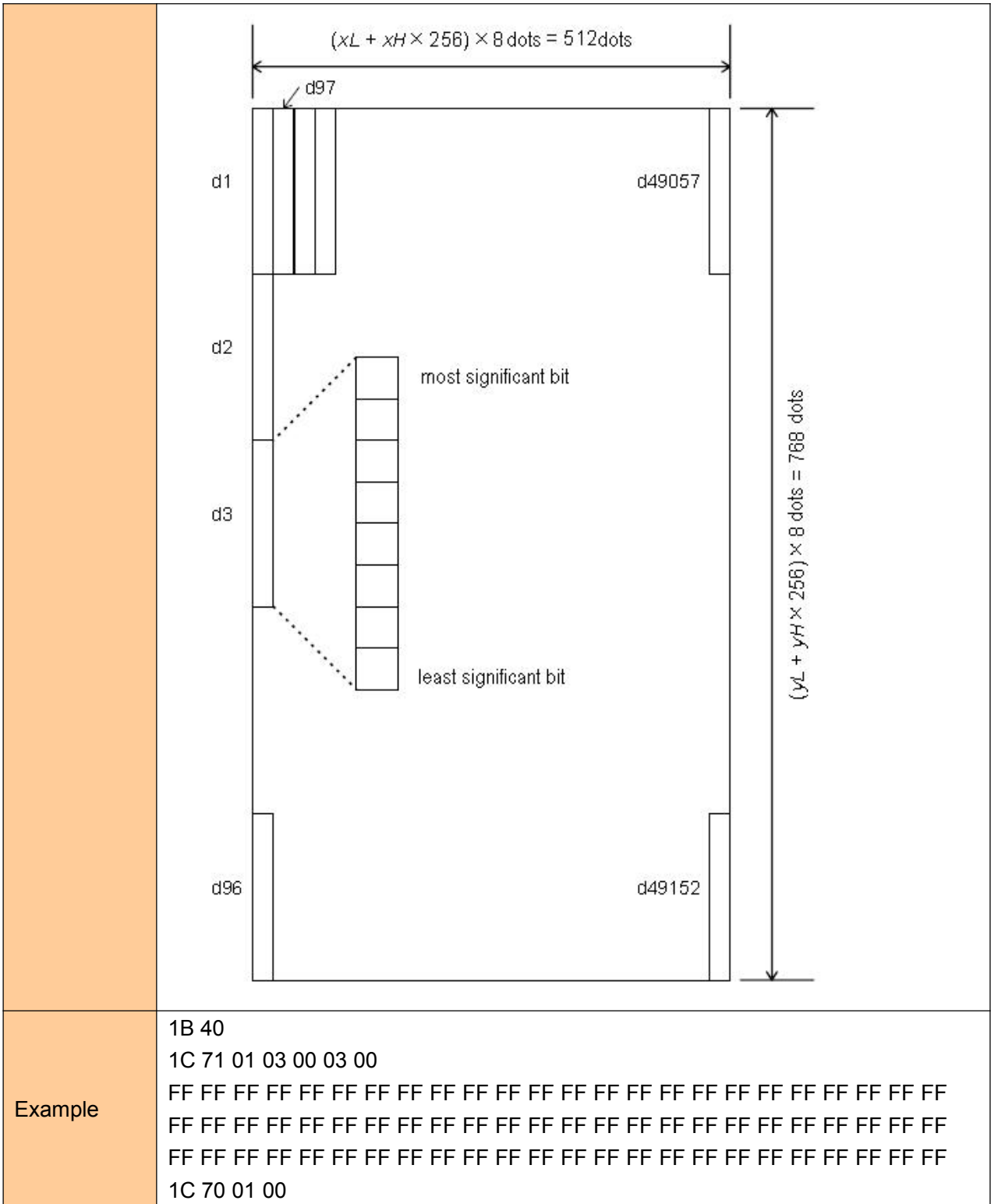

Print NV bitmap

Name	Print NV bitmap		
Code	ASCII : FS p n m DEC : 28 112 n m HEX : 1C 70 n m		
Function	Print NV bitmap n using the mode specified by m. <table border="1" style="margin-left: 20px;"> <tr> <td style="width: 20px;">m</td> <td style="width: 50px;">Mode</td> </tr> </table>	m	Mode
m	Mode		

	<table border="1"> <tr> <td>0, 48</td> <td>Normal</td> </tr> <tr> <td>1, 49</td> <td>Double-width</td> </tr> <tr> <td>2, 50</td> <td>Double-height</td> </tr> <tr> <td>3, 51</td> <td>Quadruple</td> </tr> </table>	0, 48	Normal	1, 49	Double-width	2, 50	Double-height	3, 51	Quadruple
0, 48	Normal								
1, 49	Double-width								
2, 50	Double-height								
3, 51	Quadruple								
Parameter range	$0 \leq m \leq 3$ $48 \leq m \leq 51$ $1 \leq n \leq 255$								
Default	None								
Support	All								
Notes	<p>n is the number of the NV bitmap (defined using the FS q command). m specifies the bitmap mode. NV bitmap is a bitmap defined in non-volatile memory by FS q and printed by FS p. This command is not effective when the specified NV bitmap has not been defined. In standard mode, this command is effective only when there is no data in the print buffer.</p> <p>This command is not affected by print modes (Bold printing, overlapping, underline, character size, white/black reverse printing, or 90°rotated characters, etc.), except upside-down printing mode.</p> <p>If the downloaded bit-image to be printed exceeds one line, the excess data is not printed.</p> <p>This command feeds dots (for the height n of the NV bitmap) in normal and double-width modes, and (for the height n + 2 of the NV bitmap) in double height and quadruple modes, regardless of the line space specified by ESC 2 or ESC 3.</p> <p>After printing the bitmap, this command sets the print position to the beginning of the line and processes the data that follows as normal data.</p>								
Example	None								

④ Tab Commands

Horizontal tab

Name	Horizontal tab
Code	ASCII : HT DEC : 9 HEX : 09
FUNCTION	Move the print position to the next tab position
Parameter range	None
Defaults	None

Notes	<p>Tab position set by ESC D</p> <p>If the tab position is not set(the default is no horizontal position),this command will be treated as an LF command</p> <p>If the tab position exceeds the print area,the coordinates will move to the star position of the next line(as the data is full,print and wrap)</p>
Example	none

Horizontal tab position setting

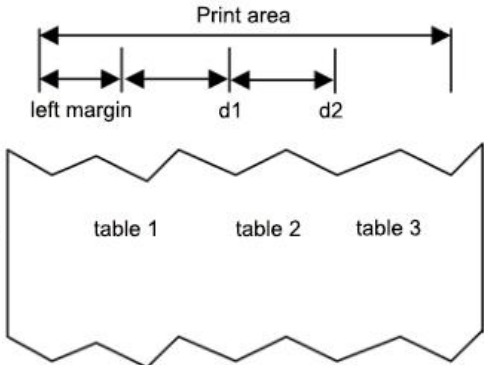

Name	horizontal tab position setting
Code	<p>ASCII : ESC D [d]k NUL</p> <p>DEC : 27 68 [d]k 0</p> <p>HEX : 1B 44 [d]k 00</p>
Function	<p>Set horizontal tab position, parameter meaning as below:</p> <p>d1 ... dk: horizontal position,in 8 as unit,null as the terminator</p>
Parameter range	<p>XX58: $1 \leq d \leq 46$ ($d_1 < d_2 < \dots < d_k$, $1 \leq k \leq 16$)</p> <p>XX80: $1 \leq d \leq 70$ ($d_1 < d_2 < \dots < d_k$, $1 \leq k \leq 16$)</p>
Defaults	The default positioning position is the 8-character interval(Column 9 17 25...) of the font A(12-24)
Support model	All
Notes	<p>Tab position as below:</p>  <p>TAB position d1 and d2 setting</p> <p>Maximum support for the setting of 16 tab position</p> <p>Using this command,the setting of previous tab position will be canceled k is for indication purpose,no transmission</p> <p>When transport [d]k,and come across NULL,should be considered over</p> <p>If dk less than or equal to dk-1,should be considered over,and balance data is treated as normal data processing</p> <p>TAB position could be changed by HT command</p> <p>When the left margin changes, the TAB position changes simultaneously</p> <p>The command setting will be valid after ESC @、 printer reset、 power off</p>
Example	1B 44 04 06 08 0A 00 09 30 09 31 09 32 09 33 0D 0A

⑤One-dimension bar code command

1D bar code readable character(HRI) print position setting



Name	1D bar code readable character(HRI)print position setting
Code	ASCII : GS H n DEC : 29 72 n HEX : 1D 48 n
Function	Set 1D bar code readable character(HRI)print position,n parameter meaning as below: n print position 0, 48 don't print 1, 49 above the bar code 2, 50 below the bar code 3, 51 above and below the bar code
Parameter range	$0 \leq n \leq 3$ or $48 \leq n \leq 51$
Defaults	n = 0
Notes	The command setting will be valid after ESC @、 printer reset、 power off
Example	None

1D bar code height setting

Name	1D bar code height setting
Code	ASCII : GS h n DEC : 29 104 n DEX : 1D 68 n
Function	Parameter n specifies the height of a bar code in dots: <div style="text-align: center;">  Height 50  Height 100 </div>
Parameter range	$1 \leq n \leq 255$
Defaults	n = 64
Notes	The command setting will be valid after ESC @、 printer reset、 power off
Example	None

1D bar code width setting

Name	1D bar code width setting
Code	ASCII : GS w n DEC : 29 119 n HEX : 1D 77 n
Function	Parameter n specifies the unit of a bar code in dots:

	 Width 3  Width 4
Parameter range	$1 \leq n \leq 6$
Defaults	$n = 2$
Noted	The command setting will be valid after ESC @、printer reset、power off
Example	None

1D bar code printing

Name	1D bar code printing																																							
Code	(A) ASCII : GS k m [d]k NUL DEC : 29 107 m [d]k NUL Hex : 1D 6B m [d]k NUL (B) ASCII : GS k m n [d]k DEC : 29 107 m n [d]k Hex : 1D 6B m n [d]k																																							
Function	1D bar code printing,the parameters meaning as below: m is encoding n is code data length,only for (command B),the difference between (A) and (B)is that the data (A) end with NULL,but (B) indicates the data length [d]k is bar code data K is the length of the bar code data,for sign,no transmission Parameters relationship as below: (Command A) <table border="1" style="width: 100%; border-collapse: collapse;"> <thead> <tr> <th rowspan="2">m</th> <th rowspan="2">Coding system</th> <th colspan="4">Bar code length (SP show space)</th> </tr> <tr> <th>Data length</th> <th>k</th> <th>Character set</th> <th>Data (d)</th> </tr> </thead> <tbody> <tr> <td>0</td> <td>UPC-A</td> <td>fixed</td> <td>k = 11, 12</td> <td>0~9</td> <td>48≤d≤57</td> </tr> <tr> <td>1</td> <td>UPC-E</td> <td>fixed</td> <td>6≤k≤8, k = 11, 12</td> <td>0~9</td> <td>48≤d≤57 [when k = 7,8,11,12, d1 = 48]</td> </tr> <tr> <td>2</td> <td>JAN13 (EAN13)</td> <td>fixed</td> <td>k = 12, 13</td> <td>0~9</td> <td>48≤d≤57</td> </tr> <tr> <td>3</td> <td>JAN8 (EAN8)</td> <td>fixed</td> <td>k = 7, 8</td> <td>0~9</td> <td>48≤d≤57</td> </tr> </tbody> </table>						m	Coding system	Bar code length (SP show space)				Data length	k	Character set	Data (d)	0	UPC-A	fixed	k = 11, 12	0~9	48≤d≤57	1	UPC-E	fixed	6≤k≤8, k = 11, 12	0~9	48≤d≤57 [when k = 7,8,11,12, d1 = 48]	2	JAN13 (EAN13)	fixed	k = 12, 13	0~9	48≤d≤57	3	JAN8 (EAN8)	fixed	k = 7, 8	0~9	48≤d≤57
m	Coding system	Bar code length (SP show space)																																						
		Data length	k	Character set	Data (d)																																			
0	UPC-A	fixed	k = 11, 12	0~9	48≤d≤57																																			
1	UPC-E	fixed	6≤k≤8, k = 11, 12	0~9	48≤d≤57 [when k = 7,8,11,12, d1 = 48]																																			
2	JAN13 (EAN13)	fixed	k = 12, 13	0~9	48≤d≤57																																			
3	JAN8 (EAN8)	fixed	k = 7, 8	0~9	48≤d≤57																																			

4	CODE39	changeable	$1 \leq k$	0~9, A~Z SP, \$, %, *, +, -, ., /	$48 \leq d \leq 57$, $65 \leq d \leq 90$, $d = 32, 36, 37,$ $42, 43, 45,$ $46, 47$
5	ITF (Interleaved 2 of 5)	changeable	$2 \leq k \leq 255$ (even numbers)	0~9	$48 \leq d \leq 57$
6	CODABAR (NW-7)	changeable	$1 \leq k$	0~9, A~D, a~d \$, +, -, ., /, :	$48 \leq d \leq 57$, $65 \leq d \leq 68$, $97 \leq d \leq 100$, $d = 36, 43, 45,$ $46, 47, 58$ ($65 \leq d_1 \leq 68$, $65 \leq dk \leq 68$, $97 \leq d_1 \leq 100$, $97 \leq dk \leq 100$)

(Command B)

m	Coding system	Bar code length (SP show space)			
		Data length	n	Character set	Data (d)
65	UPC-A	fixed	$n = 11, 12$	0~9	$48 \leq d \leq 57$
66	UPC-E	fixed	$6 \leq n \leq 8$, $n = 11, 12$	0~9	$48 \leq d \leq 57$ [when $n = 7, 8, 11, 12$, $d_1 = 48$]
67	JAN13 (EAN13)	fixed	$n = 12, 13$	0~9	$48 \leq d \leq 57$
68	JAN8 (EAN8)	fixed	$n = 7, 8$	0~9	$48 \leq d \leq 57$
69	CODE39	changeable	$1 \leq n$	0~9, A~Z SP, \$, %, *, +, -, ., /	$48 \leq d \leq 57$, $65 \leq d \leq 90$, $d = 32, 36, 37,$ $42, 43, 45,$ $46, 47$
70	ITF (Interleaved 2 of 5)	changeable	$2 \leq n \leq 255$ (even numbers)	0~9	$48 \leq d \leq 57$
71	CODAB	cha	$1 \leq n$	0~9, A~D, a~d	$48 \leq d \leq 57$,

		AR (NW-7)	changeable		\$, +, -, ., /, :	65≤d≤68, 97≤d≤100, d = 36, 43, 45, 46, 47, 58 (65≤d1≤68, 65≤dk≤68, 97≤d1≤100, 97≤dk≤100)	
	72	CODE93	changeable	1≤n≤255	00H~7FH	0≤d≤127	
	73	CODE128	changeable	1≤n≤255	00H~7FH C1H~C4H(FN C)	0≤d≤127 d = 193, 194,195,196	
	74	UCC/EAN128	changeable	1≤n≤255	00H~7FH C1H~C4H(FN C)	0≤d≤127 d = 193, 194,195,196	
Parameter range	(A) 0 ≤ m ≤ 6 (B) 65 ≤ m ≤ 74						
Defaults	None						
Notes	<p>If the bar code width exceed the printable area,the printer does not perform barcode printing</p> <p>Paper feed as needed when the command is carried out,that not affected by ESC2,ESC3 line space settings,and do not influence line space settings The command is not affected by ESC ! character style setting</p> <p>The print position is resorted to the print start location after the command is executed</p> <p>m parameter 0 ~ 6(A) and 65 ~ 71(B) select the same coding system,the same printing effect</p> <p>m parameter is 0 ~ 6(A),barcode data end with NULL</p> <p>m parameter is 65 ~ 74(B),barcode data n stand for data length</p> <p>K is for sign,no transmission</p> <p>When print UPCA (m = 0 or 65) ,Please pay attention for the following points: Whatever the input data length is 11 or 12,the check bit is automatically inserted or corrected Initial character,central split character,and terminator are inserted automatically</p> <p>When print UPCE (m = 1 or 66) ,Please pay attention as following: The system character (NSC) 0 will be inserted automatically when data length is 6 The first system character (NSC) d1 must be 0 when the data length is 7,8,11 and 12. Whatever the data length is 6,7,8,11 and 12,the check bit inserted or corrected automatically</p> <p>Whatever the input data length is 6,7,8,11,and 12,the barcode readable character(HRI) just show 6 as data,but excluded system character (NSC) and check code;</p>						

The transition relation between transmission and printing data as below:

Transmitted data										Printed data					
d2	d3	d4	d5	d6	d7	d8	d9	d10	d11	d1	d2	d3	d4	d5	d6
0~9	0~9	0	0	0	-	-	0~9	0~9	0~9	d2	d3	d9	d10	d11	0
0~9	0~9	1	0	0	-	-	0~9	0~9	0~9	d2	d3	d9	d10	d11	1
0~9	0~9	2	0	0	-	-	0~9	0~9	0~9	d2	d3	d9	d10	d11	2
0~9	0~9	3~9	0	0	-	-	-	0~9	0~9	d2	d3	d4	d10	d11	3
0~9	0~9	0~9	1~9	0	-	-	-	-	0~9	d2	d3	d4	d5	d11	4
0~9	0~9	0~9	0~9	1~9	-	-	-	-	5~9	d2	d3	d4	d5	d6	d11

When d6 is 1~9, be sure d7, d8, d9, d10 are 0, and d11 is 5~9

Initial character, terminator automatically inserted

When print EAN13(m = 2 or 67), please pay attention as following:

Whatever the input data length is 12 or 13, check bit is automatically inserted or corrected

Initial character, central split character and terminator inserted automatically

When print EAN8(m = 3 or 68), please pay attention as following:

Whatever input data length is 7 or 8, the check bit is automatically inserted or corrected

Initial character, central split character and terminator inserted automatically

When print CODE39(m = 4 or 69), please pay attention as following:

When d1 or dn are not Initial character/terminator "*", encoder is automatically inserted "*"

When middle of the data encounter "*", the encoder regard it as terminator, the other data as the normal data;

The check bit could not calculate and add automatically

When print ITF25(m = 5 or 70), please pay attention as following:

Initial character and terminator inserted automatically

The check bit could not calculate and add automatically

When print CODABAR (NW-7) (m = 6 or 71), please pay attention as following:

Initial character and terminator could not inserted automatically, but manual addition by user, that the range from "A"~"D" or "a"~"d"

Check bit could not calculate and add automatically

When print CODE93(m = 72), please pay attention as following:

Initial character and terminator inserted automatically

The two check code are automatically calculated and then inserted

When barcode readable character(HRI) is set to print, there is no HRI character which indicating start/end

When barcode readable character(HRI) is set to print, the control character will be replaced with space

When print CODE128(m = 73),please pay attention as following:
 The encoding system intelligently identifies data and implements minimum length encoding without the user set character (include starting character set) or switch character
 Function character FNC1~FNC4 use C1H~C4H and input it
 The check bit could calculate and add automatically
 When barcode readable character(HRI) is set to print,the control character and FNC1~FNC4 will be replaced with space
 When print EAN128(m = 74),please pay attention as following:
 Basic construction as below:

Initial character set	FNC1	AI	Data part	Check bit A	Check bit B	Terminator
Inserted automatically		(d1...dk)			Inserted automatically	

Connection structure as below:

Initial character set	FNC1	AI	Data part	Check bit A	FNC1	AI	Data part	Check bit A	Check bit B	Terminator
Inserted automatically		(d1...dk)							Inserted automatically	

The encoding system intelligently identifies data and implements minimum length encoding without the user set character (include starting character set) or switch character
 Function character FNC1~FNC4 use C1H~C4H and input it
 User input data AI,which do not need (“”) for indication,encoding system inserted automatically,otherwise it will be wrong.For example,GS k 74 18 "019501234567890*", 01 is AI,the following will be wrong:GS k 74 18 "(01)9501234567890*" insert
 When user use the connection structure,need to insert FNC1(C1H"Decimal=193") in the middle.The input example as following:
 GS k 74 18 "019501234567890*" 193 "029501234567890*" insert
 When barcode readable character(HRI) is set to print,the control character will be replaced with space,then cancel FNC1~FNC4

Example
 1b 40 1d 48 02
 1d 6b 41 0c 31 32 33 34 35 36 37 38 39 30 31 32
 1d 6b 42 0c 30 32 33 34 35 36 30 30 30 30 38 39
 1d 6b 43 0c 30 32 33 34 35 36 30 30 30 30 38 39
 1d 6b 44 08 30 32 33 34 35 36 30 30
 1d 6b 45 08 30 32 33 34 35 36 30 30
 1d 6b 46 08 30 32 33 34 35 36 30 30

	1d 6b 47 08 41 32 33 34 35 36 30 41
	1d 6b 48 08 41 30 32 33 34 35 36 41
	1d 6b 49 08 41 30 32 33 34 35 36 41

⑥ Status querying Commands

Real-time transmission status

Name	Real-time transmission status
Code	ASCII : DLE EOT n DEC : 16 4 n HEX : 10 04 n
Function	According to below parameters, transit the real-time status of printer,n stands for printer status: N=1:transmit printer status N=2:transmit off-line status N=3:transmit error status N=4:transmit paper sensor status
Range	$1 \leq n \leq 4$
Default	None
Support	All

Notes

- Printer return to the relative status immediately after receiving the command
 - this command try not to put in command list between 2 or more bite .
- Though printer being forbid by ESC=,this command still effective.
- Printer transmit current situation ,each situation show by 1 bite data.
- It is not sure host computer will receive printer transmit situation.
- Printer executed immediately after received the command.
- The command only effective for serial printer.Printer start to work immediately after receiving this command at any situation.

n=1: printer status

Bit	0/ 1	Hexadecimal	Decimal	Function
0	0	00	0	Fixed to be 0
1	1	02	2	Fixed to be 1
2	0	00	0	Two drawers kick(no drawer, fixed to be 0)
	1	04	4	Turn off two cash drawer
3	0	00	0	On-line
	1	08	8	Off-line
4	1	10	16	Fixed to be 1
5, 6		--	--	undefined
7	0	00	00	The paper has been torn away
	1	80	96	The paper hasn't been torn away

n=2: transit off-line status

bite	0 / 1	Hexadecimal	Decimal	Function
0	0	00	0	Fixed to be 0
1	1	02	2	Fixed to be 1
2	0	00	0	Turn off upper cover
	1	04	4	Open upper cover

3	0	00	0	Not press feed key
	1	08	8	press feed key
4	1	10	16	Fixed to be 1
5	0	00	0	Paper adequate
	1	20	32	Paper shortage
6	0	00	00	No error
	1	40	64	Error
7	0	00	0	Fixed to be 0

n=3: transmit error status

bite	0 / 1	Hexadecimal	Decimal	Function
0	0	00	0	Fixed to be 0
1	1	02	2	Fixed to be 1
2		--	--	Undefined
3	0	00	0	No cutter error
	1	08	8	Cutter error
4	1	10	16	Fixed to be 1
5	0	00	0	No unrecoverable error
	1	20	32	Unrecoverable error
6	0	00	00	Printer head temp and voltage are normal
	1	40	64	Printer head temp.and voltage are exceed
7	0	00	0	Fixed to be 0

Unrecoverable error: abnormal input voltage

Automatic recovery error: refers to the printing head overheating error. When the printing head overheating error occurs, wait for a period of time. When the printing head temperature drops, the error will be automatically recovered.

n=4: paper sensor status

bite	0 / 1	Hexadecimal	Decimal	Function
------	-------------	-------------	---------	----------

		1			
	0	0	00	0	Fixed to be 0
	1	1	02	2	Fixed to be 1
	2, 3	0	00	0	Paper
		1	0C	12	Paper near-end
	4	1	10	16	Fixed to be 1
	5, 6	0	00	0	Paper
		1	60	96	Paper end
	7	0	00	0	Fixed to be 0
Example	10 04 01 10 04 02 10 04 03 10 04 04				

⑦ Two-dimensional bar code commands

Mode type of QR code

Name	Mode type of QR code
Code	ASCII : GS (k pL pH cn fn n Decimal : 29 40 107 pL pH cn fn n Hexadecimal : 1D 28 6b pL pH cn fn n
Function	Setting mode type of QR code
Parameter range	pL=3, pH=0 cn=49 fn=67 $0 \leq n \leq 16$
Default	n=3
Notes	Setting mode type of QR code to [n dot × n dot].

Example	None
---------	------

Setting error correction level of QR code

Name	Setting error correction level of QR code																
Code	ASCII : GS (k pL pH cn fn n DEC : 29 40 107 pL pH cn fn n HEX : 1D 28 6b pL pH cn fn n																
Function	Setting error correction level of QR code																
Parameter range	pL=3, pH=0 cn=49 fn=69 $48 \leq n \leq 51$																
Default	n=48																
Notes	Setting error correction level of QR code <table border="1" style="margin-left: 20px;"> <thead> <tr> <th>n</th> <th>Function</th> <th>Approximate Amount of correction</th> </tr> </thead> <tbody> <tr> <td>4 8</td> <td>Error correction level (L)</td> <td>7%</td> </tr> <tr> <td>4 9</td> <td>Error correction level (M)</td> <td>15%</td> </tr> <tr> <td>5 0</td> <td>Error correction level(Q)</td> <td>25%</td> </tr> <tr> <td>5 1</td> <td>Error correction level (H)</td> <td>30%</td> </tr> </tbody> </table>		n	Function	Approximate Amount of correction	4 8	Error correction level (L)	7%	4 9	Error correction level (M)	15%	5 0	Error correction level(Q)	25%	5 1	Error correction level (H)	30%
n	Function	Approximate Amount of correction															
4 8	Error correction level (L)	7%															
4 9	Error correction level (M)	15%															
5 0	Error correction level(Q)	25%															
5 1	Error correction level (H)	30%															
Example	None																

Store QR code data to QR code data buffer

Name	Store QR code data to QR code data buffer	
Code	ASCII : GS (k pL pH cn fn m d1...dk DEC : 29 40 107 pL pH cn fn m d1...dk HEX : 1D 28 6b pL pH cn fn m d1...dk	
Function	Store QR code data to QR code data buffer	
Parameter range	$4 \leq (pL + pH \times 256) \leq 7092$ ($0 \leq pL \leq 255, 0 \leq pH \leq 28$) cn=49 fn=80 m=48 $0 \leq d \leq 255$ $k = (pL + pH \times 256) - 3$	
Default	No	
Notes	Store two-dimensional code data (d1...dk) to data buffer. ((pL + pH×256) - 3) bytes is processed as a graphic data after the m (d1... dk).	

Example	None
---------	------

Printing QR code

Name	Printing QR code
Code	ASCII : GS (k pL pH cn fn m DEC : 29 40 107 pL pH cn fn m HEX : 1D 28 6b pL pH cn fn m
Function	Printing QR code
Parameter range	pL=3, pH=0 cn=49 fn=81 m=48
Default	None
Notes	Printing QR code. Users must consider QR code graph space. (The space of up and down, left and right of QR code graph is specified in the specification.)
Example	1b 40 1d 28 6b 03 00 31 43 03 1d 28 6b 03 00 31 45 30 1d 28 6b 06 00 31 50 30 41 42 43 1b 61 01 1d 28 6b 03 00 31 52 30 1d 28 6b 03 00 31 51 30

Setting QR code graph information

Name	Setting QR code graph information
Code	ASCII : GS (k pL pH cn fn m DEC : 29 40 107 pL pH cn fn m HEX : 1D 28 6b pL pH cn fn m

Function	Setting QR code graph information The detailed graph information is as follows:																																												
	<table border="1"> <thead> <tr> <th>Transmit data</th> <th>Hexadecimal</th> <th>Decimal</th> <th>Data type</th> </tr> </thead> <tbody> <tr> <td>Header</td> <td>37H</td> <td>55</td> <td>1byte</td> </tr> <tr> <td>Flag</td> <td>36H</td> <td>54</td> <td>1byte</td> </tr> <tr> <td>Width</td> <td>30H-39H</td> <td>48-57</td> <td>1-5byte</td> </tr> <tr> <td>Separator</td> <td>1FH</td> <td>31</td> <td>1byte</td> </tr> <tr> <td>Height</td> <td>30H-39H</td> <td>48-57</td> <td>1-5byte</td> </tr> <tr> <td>Separator</td> <td>1FH</td> <td>31</td> <td>1byte</td> </tr> <tr> <td>Fixed Value</td> <td>31H</td> <td>49</td> <td>1byte</td> </tr> <tr> <td>Separator</td> <td>1FH</td> <td>31</td> <td>1byte</td> </tr> <tr> <td>Other Information</td> <td>30H or 31H</td> <td>48 or 49</td> <td>1byte</td> </tr> <tr> <td>NUL</td> <td>00H</td> <td>0</td> <td>1byte</td> </tr> </tbody> </table>	Transmit data	Hexadecimal	Decimal	Data type	Header	37H	55	1byte	Flag	36H	54	1byte	Width	30H-39H	48-57	1-5byte	Separator	1FH	31	1byte	Height	30H-39H	48-57	1-5byte	Separator	1FH	31	1byte	Fixed Value	31H	49	1byte	Separator	1FH	31	1byte	Other Information	30H or 31H	48 or 49	1byte	NUL	00H	0	1byte
	Transmit data	Hexadecimal	Decimal	Data type																																									
	Header	37H	55	1byte																																									
	Flag	36H	54	1byte																																									
	Width	30H-39H	48-57	1-5byte																																									
	Separator	1FH	31	1byte																																									
	Height	30H-39H	48-57	1-5byte																																									
	Separator	1FH	31	1byte																																									
	Fixed Value	31H	49	1byte																																									
Separator	1FH	31	1byte																																										
Other Information	30H or 31H	48 or 49	1byte																																										
NUL	00H	0	1byte																																										
L and H data transmit graph: use dot for unit.																																													
Other information data transmit:																																													
“Hexadecimal=30H/Decimal=48”: Data is not printed.																																													
“Hexadecimal=31H/Decimal=49”: Data is not printed.																																													
Parameter range	pL=3, pH=0 cn=49 fn=82 m=48																																												
Default	None																																												
Notes	This command do not print QR code graph. Users must consider QR code graph space. (The space of up and down, left and right of QR code graph is specified in the specification.)																																												
Example	None																																												

Printing two dimensional code

Name	Printing two dimensional code
Code	ASCII : GS k m v r nL nH d1...dk DEC : 29 107 97 v r nL nH d1...dk HEX : 1D 6B 61 v r nL nH d1...dk
Function	Printing two dimensional code. v: describes two dimensional code specification v=0: describes automatically select two dimensional code specification r: describes error correction rank nL nH: describes data length

	d1...dk: describes two dimensional code to be printed
Parameter range	$0 \leq v \leq 17$ $1 \leq r \leq 4$ $k = nL + 256 * nH$
Default	None
Notes	Printing QR code.
Example	1b 40 1D 6B 61 08 02 08 00 30 31 32 33 34 35 36 37

⑧ Printing double QR code

Name	Printing double QR code
Code	ASCII : US Q m n p1H p1L l1H l1L ecc1 v1 d1...dn p2H p2L l2H l2L ecc2 v2 dk...dm DEC : 27 81 m n p1H p1L l1H l1L ecc1 v1 d1...dn p2H p2L l2H l2L ecc2 v2 dk...dm HEX : 1F 51 m n p1H p1L l1H l1L ecc1 v1 d1...dn p2H p2L l2H l2L ecc2 v2 dk...dm
Function	Printing double QR code
Range	QR code numbers: 0<m>3 QR code size: n(1~8) P1H,p1L specify the location of QR1: (p1H*256+p1L) L1H,l1L specify the data length of QR1: (l1H*256+l1L) Ecc1 specify error correction level about QR1: (0:7%, 1:15%,2:25%,3:30%) V1 specify QR1 version of the symbol.(1~40, 0:auto size) D1...d2 as the data of QR1; P2H,p2L specify the location of QR2: (p2H*256+p2L) L2H,l2L specify the data length of QR2: (l2H*256+l2L) Ecc2 specify error correction level about QR2: (0:7%, 1:15%,2:25%,3:30%) V2 specify QR2 version of the symbol.(1~40, 0:auto size) Dk...dm as the data of QR2
Default	None
Notes	If module size is bigger than printing width, the QR data will be treated as normal data
Example	To Print string "0123456789" in QR Code at position 32 with ecc 1 and Print string "987654321" in QR Code at position 192 with ecc 2, and module size 3, you should send command as follow。 1f 51 02 03 00 20 00 0a 01 06 30 31 32 33 34 35 36 37 38 39 00 C0 00 0a 02 00 39 38 37 36 35 34 33 32 31 30

⑨ Other commands

Printer reset

Name	Printer reset
Code	ASCII : ESC @ Decimal : 27 64

	Hex : 1B 40
Function	The ESC @ command initializes the printer as following: This command prints the data contained in the print buffer, and initializes various setup items. Restore default values for each parameter
Range	None
Default value	None
Notes	None
Example	None

Print self-test page

Name	Print self-test page
Code	ASCII : DC2 T Decimal : 18 84 Hex : 12 54
Function	Printing a self-test page which including firmware version,interface,code page and other some information
Range	None
Default value	None
Notes	None
Example	1B 40 12 54

Paper cut

Name	paper cut								
Code	① ASCII : GS V m Decimal : 29 86 m Hex : 1D 56 m ② ASCII : GS V m n Decimal : 29 86 m n Hex : 1D 56 m n								
Function	This command executes paper cutting The relationship between parameter m and the cut mode is as follows: <table border="1" style="margin-left: 20px;"> <thead> <tr> <th>M</th> <th>Mode</th> </tr> </thead> <tbody> <tr> <td>0, 48</td> <td>Full cut</td> </tr> <tr> <td>1, 49</td> <td>Partial cut</td> </tr> <tr> <td>65,66</td> <td>Feed paper and cut</td> </tr> </tbody> </table>	M	Mode	0, 48	Full cut	1, 49	Partial cut	65,66	Feed paper and cut
M	Mode								
0, 48	Full cut								
1, 49	Partial cut								
65,66	Feed paper and cut								
Range	① m = 0, 48, 1, 49 ② m = 66, 0 ≤ n ≤ 255								
Default value	None								
Notes	This command is valid only at the beginning of the line • m = 0, 48, 1, 49, Printer cut paper directly. • m = 65,66, Feeds paper to[The distance between the print position and the cutter								

	<p>+ n × (vertical motion unit)]and cuts the paper</p> <ul style="list-style-type: none"> • Moving units horizontally and vertically are set by the GS p command • The feed volume is calculated by moving units vertically.
Example	<pre>1B 40 30 30 30 0D 0A 1D 56 00 30 30 30 0D 0A 1D 56 01 30 30 30 0D 0A 1D 56 42 00</pre>

Full cut

Name	Full cut
Code	ASCII : ESC i Decimal : 27 105 Hex : 1B 69
Function	Full cut mode
Range	None
Default value	None
Notes	None
Example	<pre>1B 40 30 30 30 0D 0A 1B 69</pre>

Partial cut

Name	Partial cut
Code	ASCII : ESC m Decimal : 27 109 Hex : 1B 6D
Function	Partial cut mode
Range	None
Default value	None
Notes	None
Example	<pre>1B 40 30 30 30 0D 0A 1B 6D</pre>

Specified pulse generation

Name	Specified pulse generation
Code	ASCII : ESC p m t1 t2 Decimal : 27 112 m t1 t2 Hex : 1B 70 m t1 t2
Function	Outputs the signal specified by t1 and t2 to the connector pin m.

Range	m=0,1,48,49 $0 \leq t1 \leq 255$ $0 \leq t2 \leq 255$						
Default value	无						
Notes	1、 The pulse signal which is set by t1 and t2 is out from indicated drawer kick connector pin by parameter m. <table border="1" data-bbox="419 459 1265 595"> <thead> <tr> <th data-bbox="419 459 587 510">m</th> <th data-bbox="592 459 1265 510">Function</th> </tr> </thead> <tbody> <tr> <td data-bbox="419 510 587 555">0,48</td> <td data-bbox="592 510 1265 555">Drawer kick/Turn off the signal. (No.2pin)</td> </tr> <tr> <td data-bbox="419 555 587 595">1,49</td> <td data-bbox="592 555 1265 595">Drawer kick/Turn off the signal. (No.5pin)</td> </tr> </tbody> </table> 2、 On-time is $t1 \times 2ms$. Off time is $t2 \times 2ms$ 3、 Printer does not process this command when $T2 \leq T1$	m	Function	0,48	Drawer kick/Turn off the signal. (No.2pin)	1,49	Drawer kick/Turn off the signal. (No.5pin)
m	Function						
0,48	Drawer kick/Turn off the signal. (No.2pin)						
1,49	Drawer kick/Turn off the signal. (No.5pin)						
Example	1B 40 1B 70 00 10 32 1B 70 01 10 32						