

Quartz Crystals

HUS

[10.7 * 4.3 * 3.5 mm]

HUSL

[10.7 * 4.3 * 2.5 mm]

Thru - Hole Crystals

Fundamental

3rd Overtone

Min.

3 MHz

Max.

100 MHz

Features

Specifications

- HUSL (2.5mm height) & HUS (3.5mm height)
- Low cost and light weight



General Specifications

Item / Type	HUSL (10.7 * 4.3 * 2.5mm) series	HUS (10.7 * 4.3 * 3.5mm) series
Frequency Range & Crystal Cut	3.000 ~ 48.000 MHz , AT-cut , Fundamental Mode (see Table 1) 27.000 ~ 100.000 MHz , AT-cut , 3rd overtone (see Table 1)	
Load Capacitance	Series or Parallel (8 to 32 pF) resonance	
Drive Level	100 μW (typ.) 500 μW (max.)	
Frequency Tolerance	± 10 ppm , ± 20 ppm or ± 30 ppm (max.) at 25°C	
Frequency Stability	See Table 2	
Aging	ΔF / F : ±3 ppm year (max.)	
Storage Temperature Range	- 50°C to 105°C	

Table 1

ESR (Equivalent Series Resistance)					
Freq.(MHz)	E.S.R.	Osc. Mode	Freq.(MHz)	E.S.R.	Osc. Mode
3.0 ~ 3.4	300 Ω	AT , Fund.	27.0 ~ 30.0	150 Ω	AT , 3rd
3.5 ~ 6.0	120 Ω		30.1 ~ 50.0	100 Ω	
6.1 ~ 10.0	60 Ω		50.1 ~ 100.0	80 Ω	
10.1 ~ 48.0	40 Ω				

Table 2

Frequency stability vs Operating temperature range						
Stability code	Temp. (°C) \ ppm	± 10	± 15	± 20	± 25	± 30
X	-10 to 60°C	○	○	○	○	○
Y	-20 to 70°C	▲	○	○	○	○
I	-40 to 85°C		○	○	○	○

○ : available ; ▲ : contact Mercury

Outline Dimensions (Unit : mm)

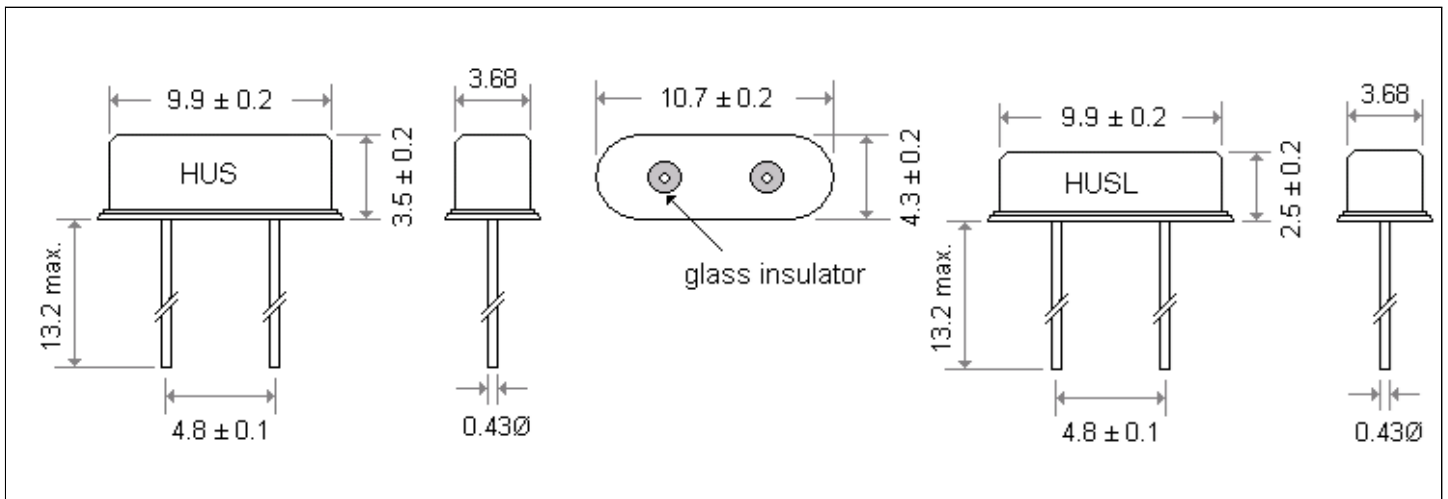

Part Number Formats and Product Marking Rules

Quartz Crystals

Holder Type

SMD type :	X11	X21	X22	X32	X42	MJ	MF	MQ	M49	ML49	MP5	MP4	MP25	MP24
Dip type :	H49	HUS	HUSL	U1	U5	T38	T26							
Jacket type :	H49MJ	49TMJ	U1MJ	U5MJ	T26MJ									
Gull wing :	H49SM	49TSM	U1SM	U5SM	T26SM									

Part Number Format

	[1] Holder Type	-	[2] Center Freq.	-	[3] CL	-	[4] Freq. Tolerance	/	[5] Freq. Stability	[6] Operating Temp. Range Code	/	[7] Special ESR
Example	(1)	H49	-	40.000A3	-	12	-	30	/	30	X	
	(2)	X32	-	26.000	-	16	-	30	/	30	X	/ 20R
	(3)	MJ	-	12.000	-	20	-	10	/	10	W	
	(4)	M49	-	24.000	-	18	-	20	/	30	H	/ 15R

- Ex (1) : H49 - 40.000A3 - 12 - 30 / 30 X [49/U type , 40.000MHz , AT-cut 3rd overtone , 12pF , ±30ppm (25°C) , ±30ppm (-10°C to 60°C)]
 Ex (2) : X32 - 26.000 - 16 - 30 / 30 X / 20R [X32 type , 26.000MHz , 16pF , ±30ppm (25°C) , ±30ppm (-10°C to 60°C) , 20 Ω]
 Ex (3) : MJ - 12.000 - 20 - 10 / 10 W [MJ type , 12.000MHz , 20pF , ±10ppm (25°C) , ±10ppm (0°C to 50°C)]
 Ex (4) : M49 - 24.000 - 18 - 20 / 30 H / 15R [M49 type , 24.000MHz , 18pF , ±20ppm (25°C) , ±30ppm (-30°C to 85°C) , 15 Ω]

[1]	Holder Type
[2]	Center frequency . Please add " A3 , A5 or B " after the " Freq. in MHz " for the quartz cut other options . Blank : AT-cut fund. mode ; A3 : AT-cut 3rd overtone ; A5 : AT-cut 5th overtone ; B : BT-cut fund. mode
[3]	Load Capacitance (CL) : series (spec. code is " S ") or Parallel (If parallel , please specify CL value , typical CL ranges from 8 to 32 pF) Available Options " V " = Vinyl sleeve around holder , " K " = 3rd lead at bottom center , " R " = On reel " G " = 3rd lead at top center , " I " = Teflon insulator at bottom
[4]	Calibration tolerance value : freq. tolerance value (at 25°C) , industrial temp. range
[5]	Frequency Stability , industrial temp. range
[6]	Temp. Range Options
[7]	If non-standard please enter the desired ESR (Equivalent Series Resistance) after " / " , for example " 20R " : 20Ω

Production Marking Rules

General X'tal package type marking rules	MQ, MF, MJ, X42 marking rules	X22, X32 marking rules
<p>(Cutting method) : A : AT-cut (fundamental) B : BT-cut (fundamental) 3 : AT-cut (3rd overtone) 5 : AT-cut (5th overtone)</p> <p>Lot code (month) : Table 2 (Year) : ex : 2020 --- 0 2021 --- 1</p> <p>Load capacitance (CL) : Table 1</p>	<p>Lot code (Month) --- Table 2 (Year) --- 2020 --- 0 Load capacitance (CL) : Table 1</p> <p>(Cutting method) : A : AT-cut , fundamental B : BT-cut , fundamental 3 : AT-cut , 3rd overtone 5 : AT-cut , 5th overtone</p>	<p>Lot code : (Month) --- Table 2 (Year) 2020 --- 0 2021 --- 1</p>
<h4>X11 marking rules</h4> <p>(Month) --- Table 2 (Year) 2020 --- 0 2021 --- 1</p>		<h4>X21 marking rules</h4> <p>(Month) --- Table 2 (Year) 2020 --- 0 2021 --- 1</p>

Table 1	CL	< 10	10	11	12	13	14	15	16	17	18	19	20	21	22	23	24	25	26	27	28	29	30	31	32	33	34	>34	Series
	Code	A	B	C	D	E	F	G	H	I	J	K	L	M	N	O	P	Q	R	S	T	U	V	W	X	Y	Z	a	b
Table 2	Month	Jan.	Feb.	Mar.	Apr.	May	Jun.	Jul.	Aug.	Sep.	Oct.	Nov.	Dec.																
	Code	A	B	C	D	E	F	G	H	I	J	K	L																

Mercury www.mercury-crystal.com ■ Taiwan : Tel: (+886)-2-2406-2779 / sales-tw@mercury-crystal.com

■ USA : Tel: (+1)-909-466-0427 / sales-us@mercury-crystal.com ■ China : Tel: (+86)-512-5763-8100 / sales-cn@mercury-crystal.com