

120A 90V N-channel Enhancement Mode Power MOSFET

1 Description

These N-channel enhancement mode power MOSFETS Used advanced Split Gate technology design, provided excellent R_{DS(on)} and low gate charge. Which accords with the RoHS standard.

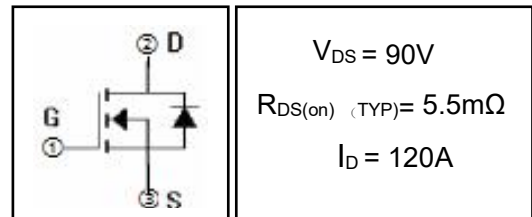

2 Features

- Fast Switching
- Low On Resistance
- Low Gate Charge
- High avalanche Current
- Low Reverse Transfer Capacitances
- 100% Single Pulse Avalanche Energy Test
- 100% ΔV_{DS} Test

3 Applications

- Motor Control and Drive
- Battery management
- Power tool control
- UPS(Uninterruptible Power Supplies)

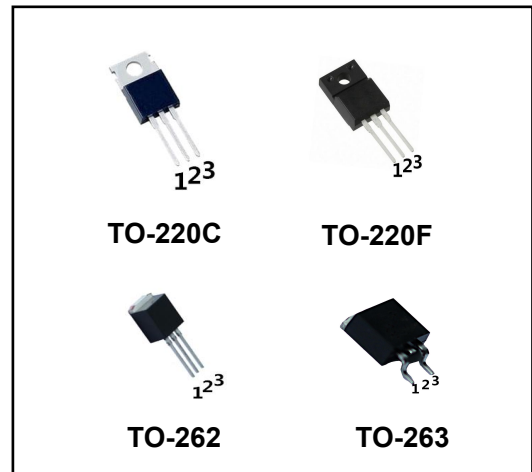

4 Electrical Characteristics

4.1 Absolute Maximum Ratings (T_c=25°C, unless otherwise noted)

Parameter	Symbol	Value		Units	
		DH90N055R/DHI90N055R/DHE90N055R	DHF90N055R		
Drain-Source Voltage	V _{DS}	90		V	
Gate-Source Voltage	V _{GS}	±20		V	
Drain Current(continuous) ^(Note 3)	I _D	120		A	
Drain Current(continuous)(T=100°C) ^(Note 3)	I _{D(100°C)}	70		A	
Drain Current(Pulsed) ^(Note 4)	I _{DM}	480		A	
Single Pulse Avalanche Energy ^(Note 5)	E _{AS}	110		mJ	
Maximum Power Dissipation	T _a =25°C	P _{tot}	2	2	W
	T _c =25°C	P _{tot}	164	75	W
Operating Junction Temperature Range	T _j	-55 ~ 150		°C	
Storage Temperature Range	T _{stg}	-55 ~ 150		°C	
High Temperature(tin solder)	T _L	300		°C	

4.2 Thermal Characteristics

Parameter	Symbol	Value		Unit
		DH90N055R/DHI90N055R/DHE90N055R	DHF90N055R	
Thermal Resistance, Junction to Case-sink	R _{thJC}	0.76	1.67	°C/W
Thermal Resistance, Junction to Ambient	R _{thJA}	62.5	62.5	°C/W

4.3 Electrical Characteristics (T_c=25°C, unless otherwise noted)

Parameter	Symbol	Test Condition	Value			Units
			Min	Typ	Max	
Off Characteristics						
Drain-source Breakdown Voltage	BV _{DSS}	I _D =250μA, V _{GS} =0V	90	98	--	V
Zero Gate Voltage Drain Current	I _{DSS}	V _{DS} =90V, V _{GS} =0V, T _C =25°C	--	--	1	μA
		V _{DS} =72V, V _{GS} =0V, T _C =125°C	--	--	100	μA
Gate-to-Body Leakage Current	I _{GSS}	V _{GS} =±20V, V _{DS} =0V	--	--	±100	nA
On Characteristics (Note 3)						
Gate threshold voltage	V _{GS(th)}	V _{DS} =V _{GS} , I _D =250μA	2	3	4	V
Drain-source on Resistance	R _{DS(on)}	V _{GS} =10V, I _D =50A	--	5.5	6.5	mΩ
Dynamic Characteristics (Note 4)						
Forward Transfer conductance	g _{fs}	V _{DS} =5V, I _D =40A	--	70	--	S
Input Capacitance	C _{iss}	V _{GS} =0V, V _{DS} =42.5V, f=1.0MHz	--	2860	--	pF
Output Capacitance	C _{oss}		--	790	--	
Reverse Transfer Capacitance	C _{rss}		--	19	--	
Gate Resisitance	R _G	V _{DD} =0V, V _{GS} =0V, F=1MHz	--	3.3	--	Ω
Switching Characteristics (note4)						
Turn-on Delay Time	t _{d(on)}	V _{DD} =42.5V, I _D =10A, V _{GS} =10V, R _G =3.5Ω	--	11	--	nS
Turn-on Rise Time	t _r		--	16	--	
Turn-off Delay Time	t _{d(off)}		--	31	--	
Turn-off Fall Time	t _f		--	36	--	
Total Gate Charge	Q _g	I _D =50A, V _{DS} =42.5V, V _{GS} =10V	--	47	--	nC
Gate-to-Source Charge	Q _{gs}		--	13	--	
Gate-to-Drain("Miller")Charge	Q _{gd}		--	11	--	
Drain-Source Diode Characteristics						
Diode Forward Voltage ^(N ote 3)	V _{SD}	V _{GS} =0V, I _S =50A	--	0.9	1.4	V
Diode Forward Current ^(N ote 2)	I _S		--	--	120	A
Reverse Recovery Time	t _{rr}	T _J =25°C, I _F =30A, di _F /dt=100A/μS, V _{GS} =0V	--	56	--	nS
Reverse Recovery Charge	Q _{rr}		--	54	--	nC

Notes:

- 1: Repetitive rating, pulse width limited by maximum junction temperature.
- 2: Surface mounted on FR4 Board, t_s≤10sec.
- 3: Pulse width ≤ 300μs, duty cycle ≤ 2%.
- 4: Guaranteed by design, not subject to production.
- 5: L=0.5mH, I_D=21A, V_{DD}=50V, V_{GATE}=80V, Start T_J=25°C.

5 Typical characteristics diagrams

Fig 1: Output Characteristics

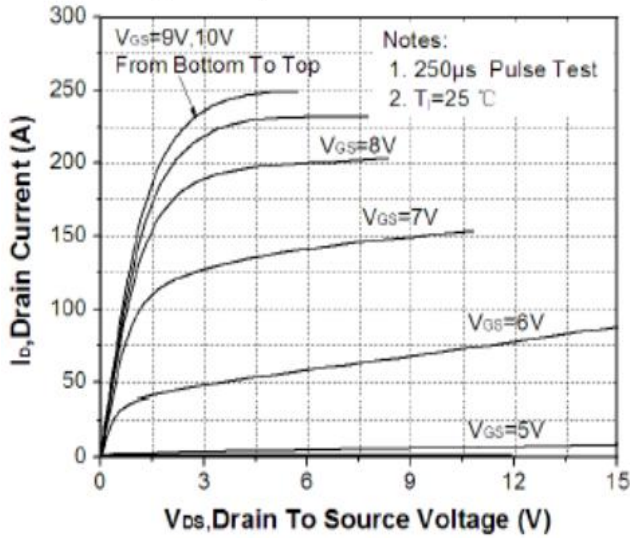

Fig 2: Transfer Characteristics

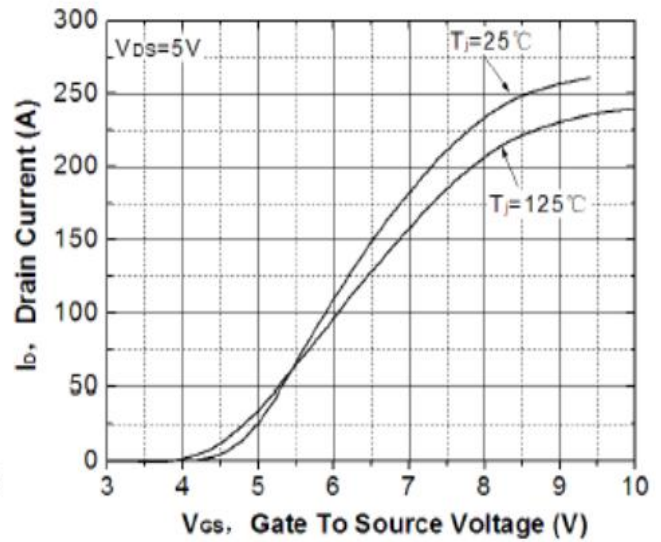

Fig 3: R_{ds(on)} vs Drain Current and Gate Voltage

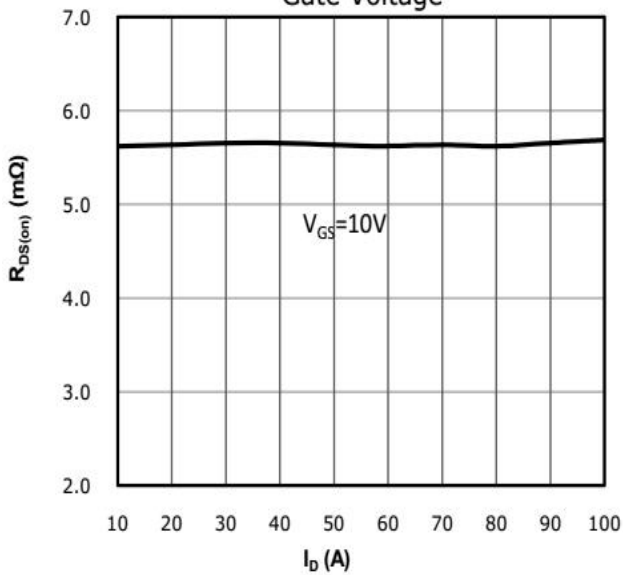
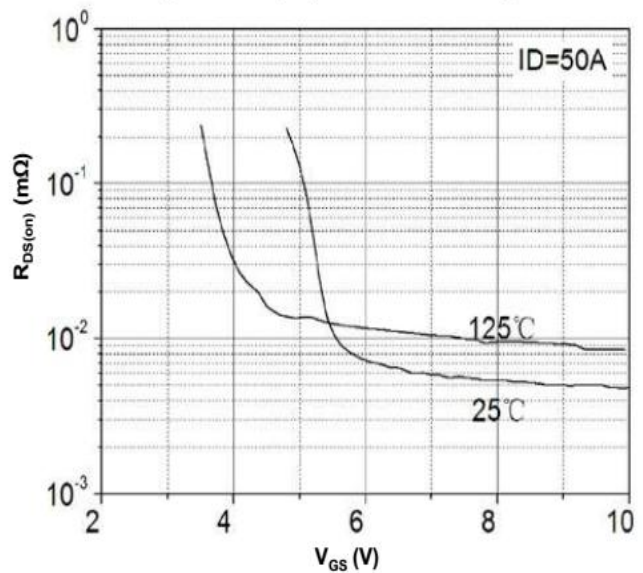

Fig 4: R_{ds(on)} vs Gate Voltage



5 Typical characteristics diagrams(continues)

Fig 5: Rds(on) vs. Temperature

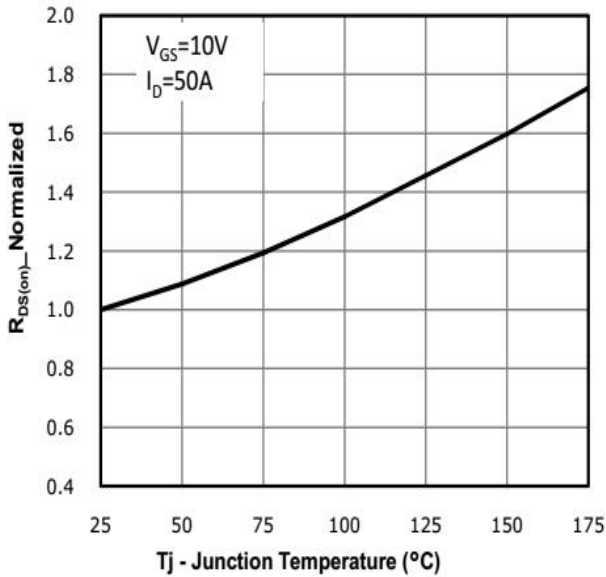

Fig 6: Capacitance Characteristics

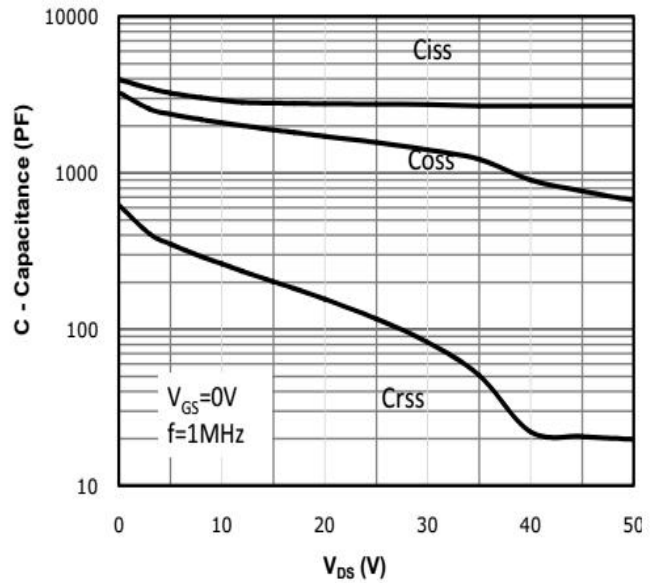

Fig 7: Gate Charge Characteristics

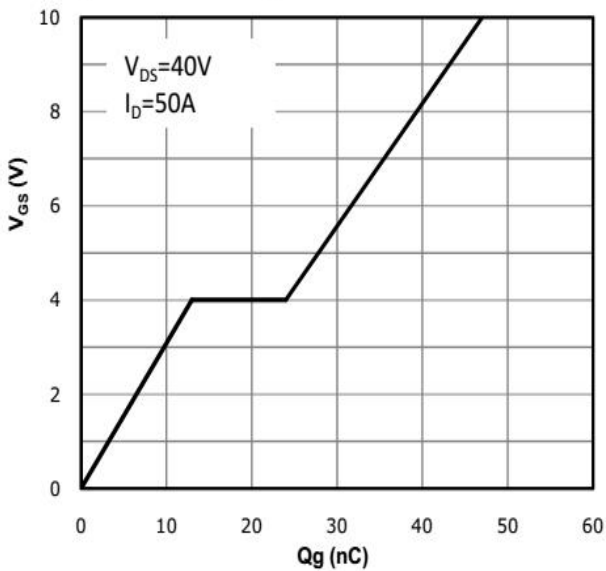
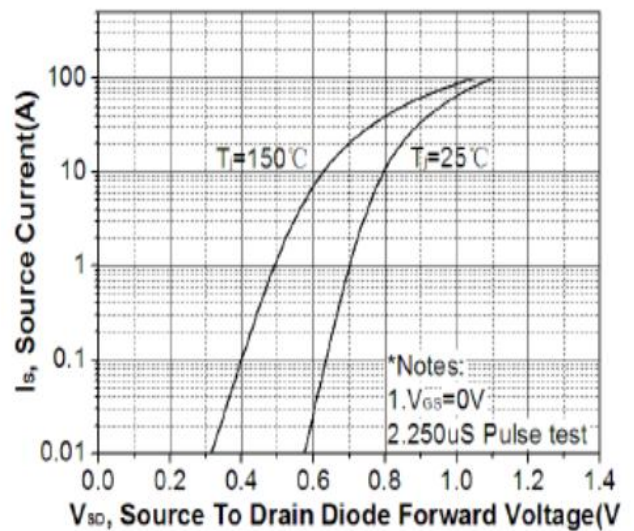

Fig 8: Body-diode Forward Characteristics



5 Typical characteristics diagrams(continues)

Fig 9: Power Dissipation

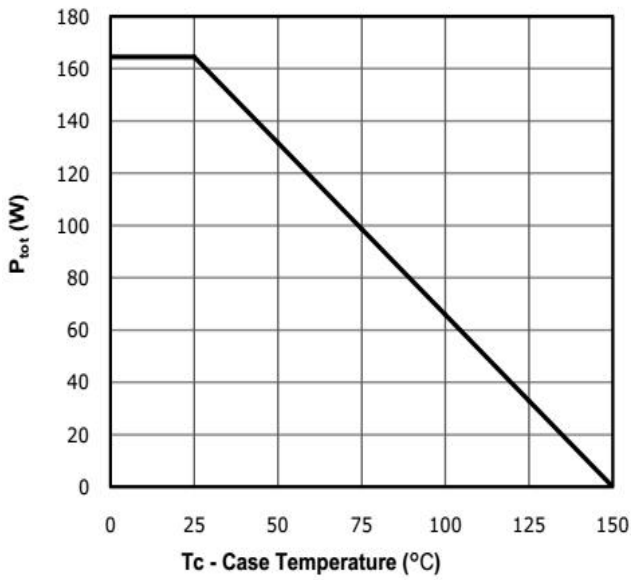

Fig 10: Drain Current Derating

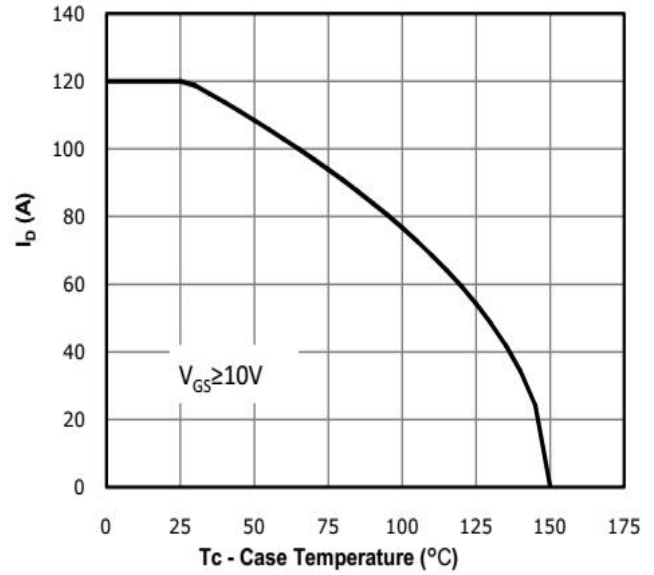
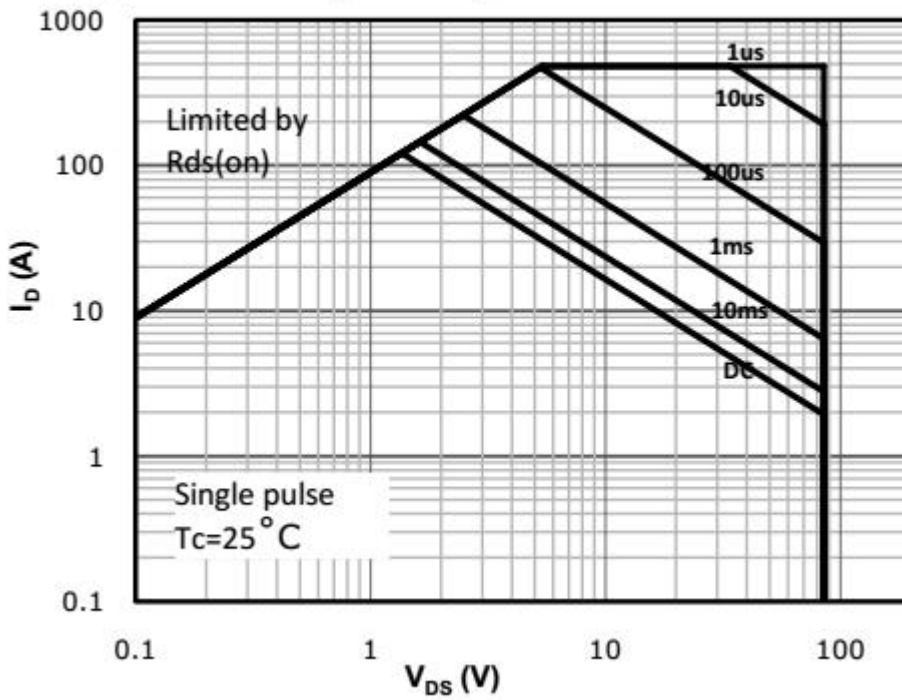
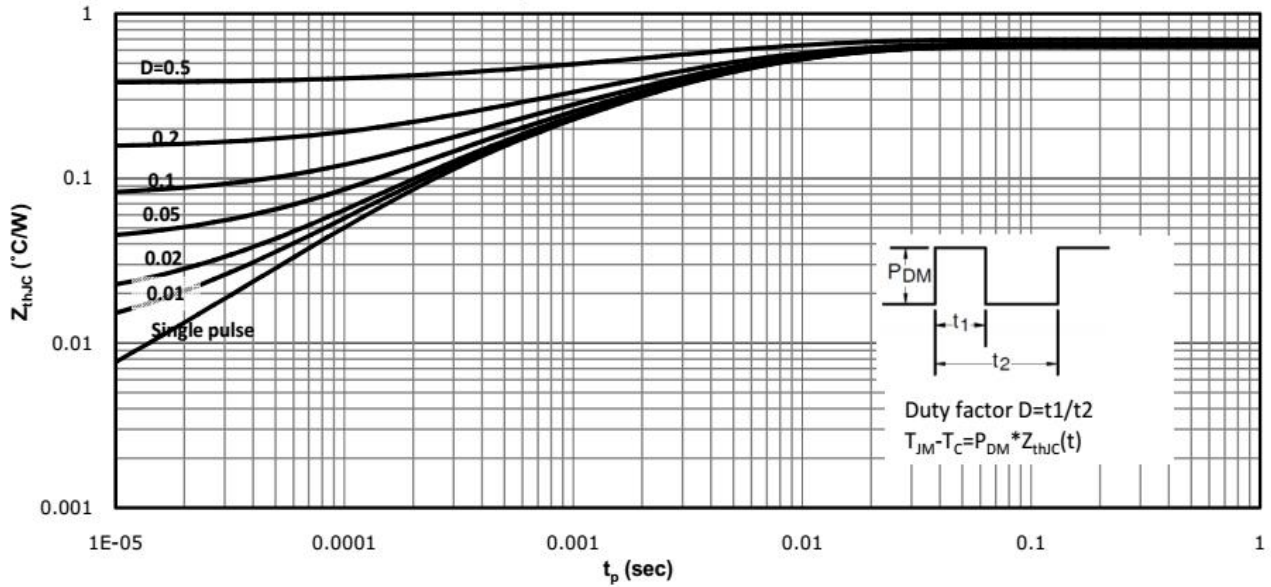

Fig 11: Safe Operating Area



5 Typical characteristics diagrams(continues)

Fig 12: Max. Transient Thermal Impedance



6 Typical Test Circuit and Waveform

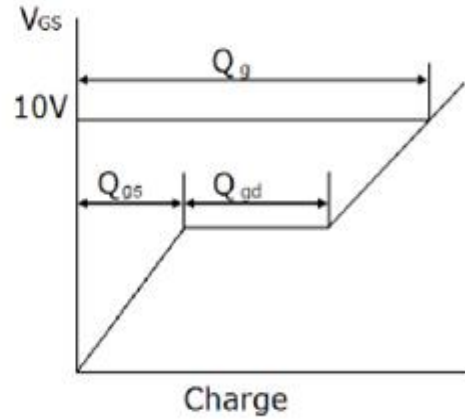
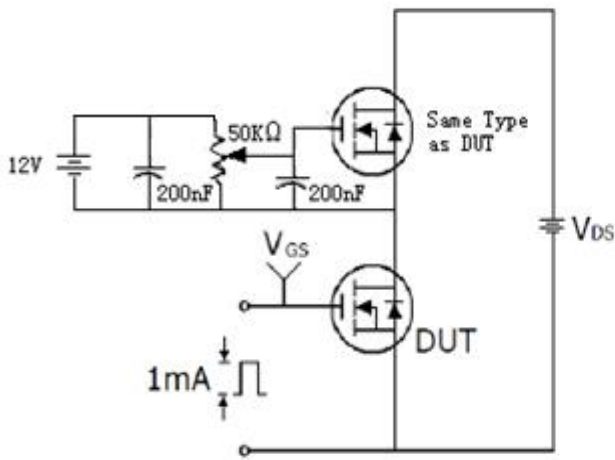

1) Gate charge test circuit & Waveform

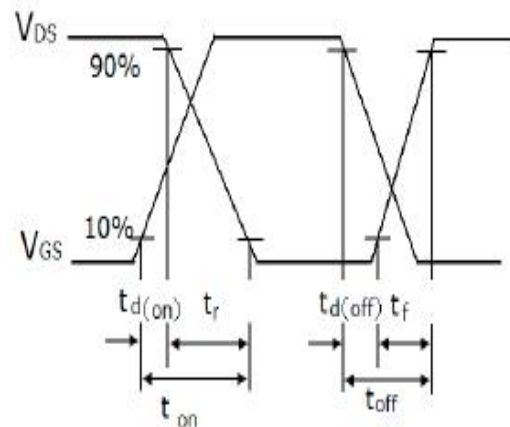
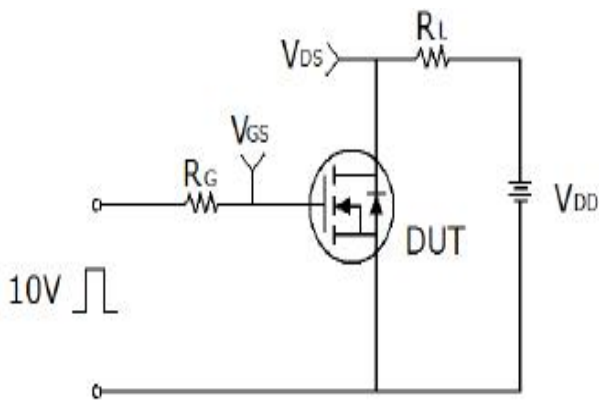

2) Switch Time Test Circuit:

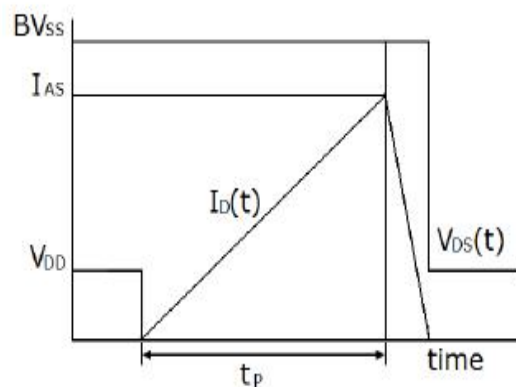
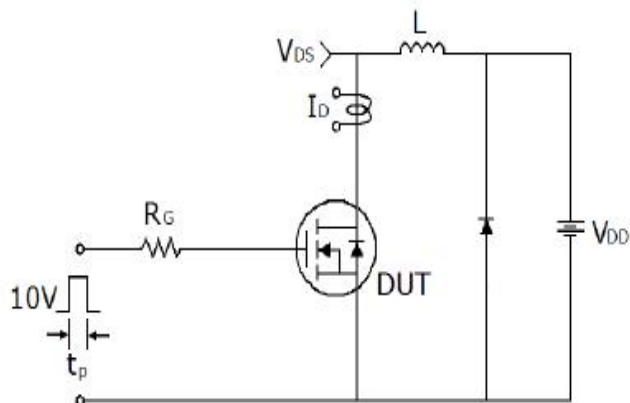

3) Unclamped Inductive Switching Test Circuit & Waveforms

7 Product Names Rules

D H F X X N E X X X R

LOGO Code: DH

Packaging Code
220F: F 220: Nothing
251: B 252: D
262: I 263: E

Rated Voltage Code
With 2 Digitals,
For Example:
90 on behalf of 90V,
10H on behalf of 100v

Channel Polarity Code
N on behalf of N channel
P on behalf of P channel

RDSON Number Code: R

RDSON Specification Code
With 3 Digitals,
For Example:
045 on behalf of 4.5mΩ,
050 on behalf of 5.0mΩ,
055 on behalf of 5.5mΩ

Special Function Code
E on behalf of build-in ESD
Nothing on behalf of not ESD

8 Product Specifications and Packaging Models

Product Model	Package Type	Mark Name	RoHS	Package	Quantity
DH90N055R	TO-220C	DH90N055R	Pb-free	Tube	1000/box
DHF90N055R	TO-220F	DHF90N055R	Pb-free	Tube	1000/box
DHI90N055R	TO-262	DHI90N055R	Pb-free	Tube	1000/box
DHE90N055R	TO-263	DHE90N055R	Pb-free	Tape & Reel	800/box

9 Dimensions

TO-220C PACKAGE OUTLINE DIMENSIONS

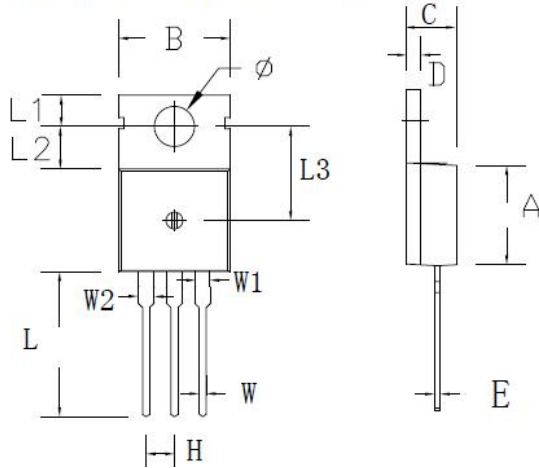

Symbol	Dimensions In Millimeters		Dimensions In Inches	
	min.	max.	min.	max.
A	8.80	9.30	0.346	0.366
B	9.70	10.30	0.382	0.406
C	4.25	4.75	0.167	0.187
D	1.20	1.45	0.047	0.057
E	0.40	0.60	0.016	0.024
H	2.54 TYP		0.100 TYP	
W	0.60	0.95	0.024	0.037
W1	1.05	1.45	0.041	0.057
W2	1.20	1.60	0.047	0.063
L	12.60	13.40	0.496	0.528
L1	2.45	2.95	0.096	0.116
L2	3.45	3.95	0.136	0.156
L3	8.15	8.65	0.321	0.341
ϕ	3.50	3.90	0.138	0.154

TO-220F PACKAGE OUTLINE DIMENSIONS

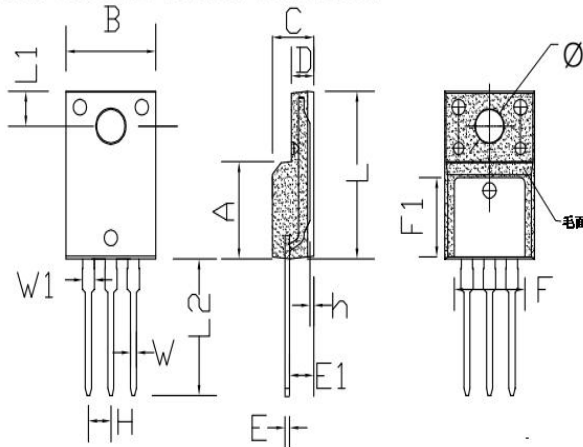

Symbol	Dimensions In Millimeters		Dimensions In Inches	
	min.	max.	min.	max.
A	8.80	9.30	0.346	0.366
B	10.00	10.50	0.394	0.413
C	4.30	4.90	0.169	0.193
D	2.30	2.70	0.091	0.106
L	15.55	16.15	0.612	0.636
h	0.40	0.60	0.016	0.024
L1	3.15	3.55	0.124	0.140
L2	12.65	13.35	0.498	0.526
W	0.70	0.90	0.028	0.035
W1	1.15	1.55	0.045	0.061
H	2.54 TYP		0.100 TYP	
E	0.48	0.53	0.019	0.021
ϕ	2.90	3.40	0.114	0.134
E1	2.40	2.90	0.094	0.114
F	7.75	8.25	0.305	0.325
F1	7.35	7.85	0.289	0.309

9 Dimensions(continues)

TO-262 PACKAGE OUTLINE DIMENSIONS

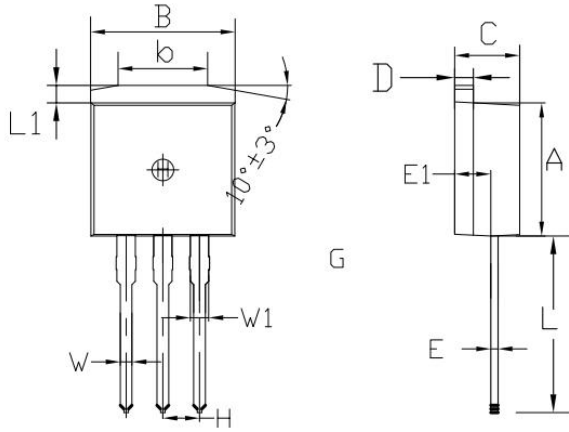

Symbol	Dimensions In Millimeters		Dimensions In Inches	
	min.	max.	min.	max.
A	8.80	9.30	0.346	0.366
B	9.70	10.30	0.382	0.406
C	4.25	4.75	0.167	0.187
D	1.20	1.45	0.047	0.057
E	0.40	0.60	0.016	0.024
L	12.25	13.75	0.482	0.541
L1	1.15	1.45	0.045	0.057
E1	2.4	2.6	0.0945	0.1024
W	0.80	0.82	0.0315	0.034
W1	1.20	1.30	0.047	0.051
H	2.54 TYP		0.200 TYP	
b	5.50	6.50	0.216	0.256

TO-263 PACKAGE OUTLINE DIMENSIONS

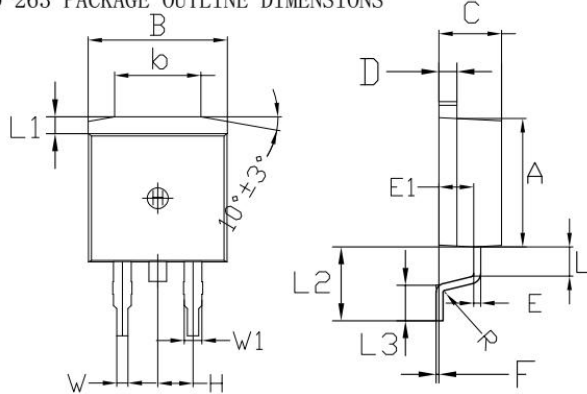

Symbol	Dimensions In Millimeters		Dimensions In Inches	
	min.	max.	min.	max.
A	8.80	9.30	0.346	0.366
B	9.70	10.30	0.382	0.406
C	4.25	4.75	0.167	0.187
D	1.20	1.45	0.047	0.057
E	0.40	0.60	0.016	0.024
L	1.90	2.30	0.075	0.091
L1	1.15	1.45	0.045	0.057
R	0.24	0.26	0.0095	0.0102
W	0.80	0.82	0.0315	0.0323
W1	1.20	1.30	0.047	0.051
H	2.54 TYP		0.200 TYP	
b	5.50	6.50	0.216	0.256
E1	2.4	2.6	0.0946	0.1024
L2	5.20	5.80	0.205	0.228
L3	2.20	3.20	0.087	0.126
F	0.03	0.23	0.0012	0.0091

10 Attentions

- ROUM Semiconductor Technology CO.,LTD. reserves the right to change the specification without prior notice! The customer should obtain the latest version of the information before making the order and verify that the information is complete and up to date.
- It is the responsibility of the purchaser for any failure or failure of any semiconductor product under certain conditions. It is the responsibility of the purchaser to comply with safety standards and to take safety measures in the system design and machine manufacturing of Roma products in order to avoid potential risk of failure. Injury or property damage.
- Product promotion is endless, our company will be dedicated to provide customers with better products.

11 Appendix

Revision history:

Date	REV.	Description	Page
2017.08.09	1.0	Original	