

AC / DC Sensing Current Sensor with Digital Data output**Feature:**

- Small package with digital current output
- Continuous, AT Command, Modbus-RTU
- Operating voltage DC5.0V
- Temperature compensation
- Diameter 9.0mm conductor through hole
- Sensing current range:
AC: 0~17A (50Hz, 60Hz)
DC: 0~±25A
- High accuracy:
AC: (0~8A) ± 0.16A
(8~17A) ± 2%
- DC: ±(0~8A) ± 0.16A
±(8~25A) ± 2%
- Resolution: 74mA
- UART digital data output · Baud Rate : 9600 bps
- Isolation voltage 4KV
- Application note: <http://www.winson.com.tw/Product/83>

**General Description:**

The Winson DWCS1800 is a AC/DC current sensor with calibrated digital signal output. It applies exclusive digital signal collecting technique and allows for easy implementation without breaking original system. Typical applications include load detection and management, over-current fault detection and any intelligent power management system etc...

The DWCS1800 consists of a precise, low-temperature drift linear hall sensor IC with temperature compensation circuit, temperature sensor, digital signal processor and through-hole mechanism with a diameter of 9.0mm etc.

All the sensors on DWCS1800 are temperature compensated and calibrated with accurate calibration instrument. The UART interface directly transmits digital current signals, making system integration simple and fast. Small size, low consumption and the terminals of the conductive path are electrically isolated from the sensor leads enable DWCS1800 to be suited in all kinds of harsh application occasions.

Winson reserves the right to make changes to improve reliability or manufacturability.

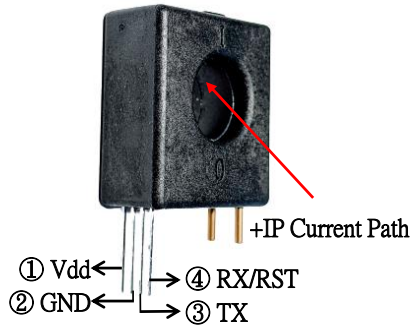

Absolute Maximum Range

Supply Voltage, Vdd -----	6V
Pass Through Wire Diameter -----	9.0mm
Basic Isolation Voltage -----	4000V
Operating Temperature Range, Ta -----	-40°C to +105°C
Storage Temperature Range, Ts -----	-60°C to +125°C

Note: Stresses above those listed may cause permanent damage to the devices

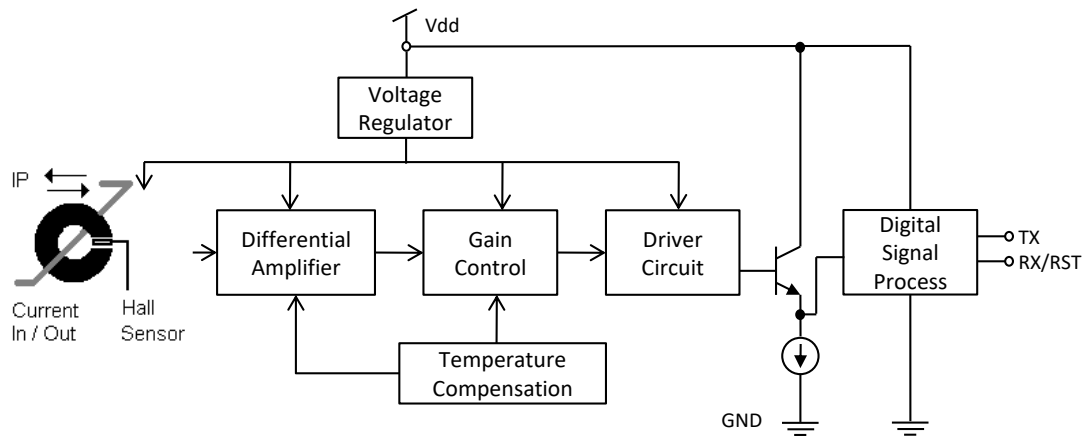

Functional Block Diagram

Selection Guide:

Model	Maximum Current		Operating Voltage	Frequency	Version
	AC	DC			
DWCS1800-AC50C	17A	-	5.0V	50Hz/60Hz	Continuous
DWCS1800-DC50C	-	25A	5.0V	DC	Continuous
DWCS1800-50C	17A	25A	5.0V	50Hz/60Hz,DC	AT Command
DWCS1800-50M	17A	25A	5.0V	50Hz/60Hz,DC	Modbus-RTU

Note:

Continuous: UART Interface, continuous transmission, external reset method (RST pull low to GND).

AT Command & Modbus-RTU: UART interface, command transmission, internal reset method (UART command).

Pad Description:

Pad No	Pad Name	I/O	Description
1	VDD	-	The positive power input pin
2	GND	-	The system ground

Winson reserves the right to make changes to improve reliability or manufacturability.

3	TX	O	The current data output, UART interface, baud rate 9600 bits/sec
4	RX/RST	I	RST(Continuous): External Reset, RX(AT Command & Modbus-RTU): Internal UART Reset

Electrical Characteristics: Common Operating Characteristics

Symbol	Parameter	Test Condition	Min.	Typ.	Max.	Unit
V _{DD}	Operation Voltage	-	4.9	5	5.1	V
I _{DD}	Operation Current	V _{DD} = 5.000V	-	6	10	mA
-	Conductor Through Hole	-	-	9	-	mm ²
T _{OP}	Operating Temperature	-	-20	-	70	°C
A _{CC}	Internal Temperature Accuracy	V _{DD} = 5.000V	-	-	5	°C

-AC50C

V_{DD} = 5.000V

Symbol	Parameter	Test Condition	Min.	Typ.	Max.	Unit
I _{OP}	Current Range	-	0	-	17	A
E _{TOT}	Current Output Error	I _{OP} = 0~8A, T _{op} = 25 °C	-	±0.16	-	A
		I _{OP} = 8~17A, T _{op} = 25 °C	-	±2	-	%
		I _{OP} = 0~17A, -20 °C < T _{op} < 70 °C	-	±5	-	%

-DC50C

V_{DD} = 5.000V

Symbol	Parameter	Test Condition	Min.	Typ.	Max.	Unit
I _{OP}	Current Range	-	0	-	17	A
E _{TOT}	Current Output Error	I _{OP} =0~8A, T _{op} = 25 °C	-	±0.16	-	A
		I _{OP} =8~25A, T _{op} = 25 °C	-	±2	-	%
		I _{OP} =0~25A, -20 °C < T _{op} < 70 °C	-	±5	-	%

Winson reserves the right to make changes to improve reliability or manufacturability.

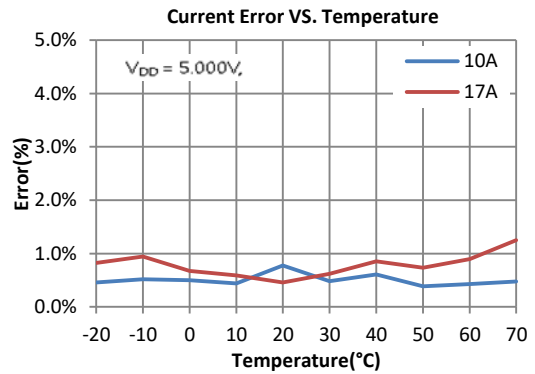
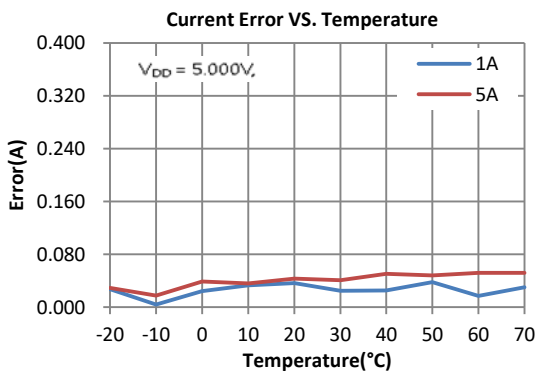
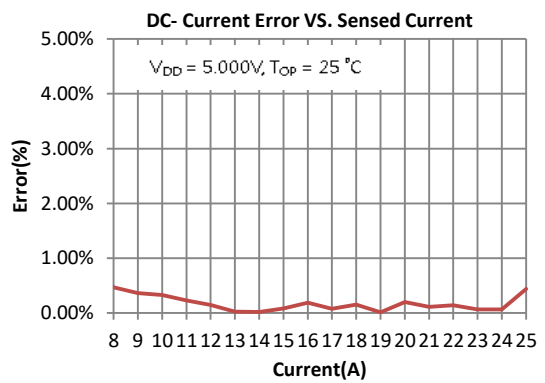
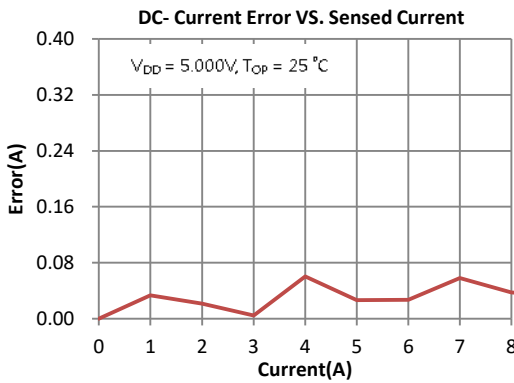
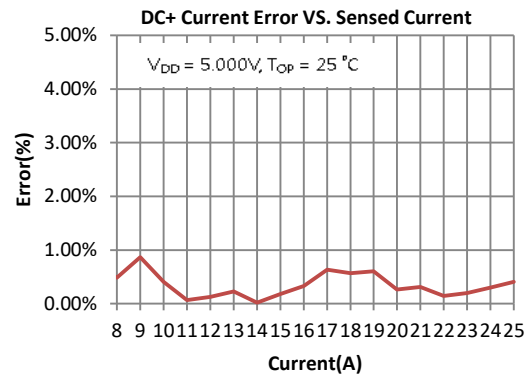
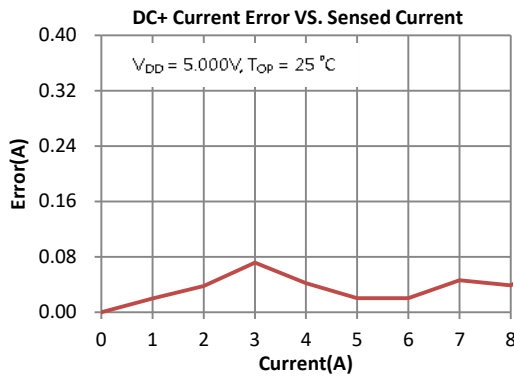
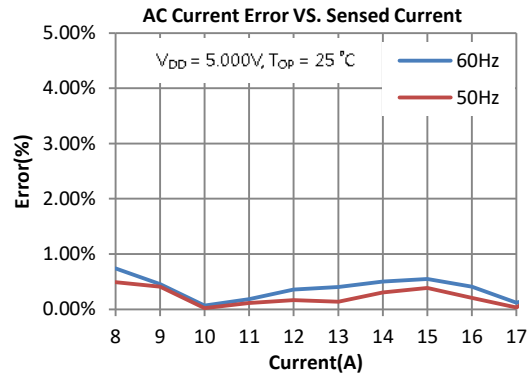
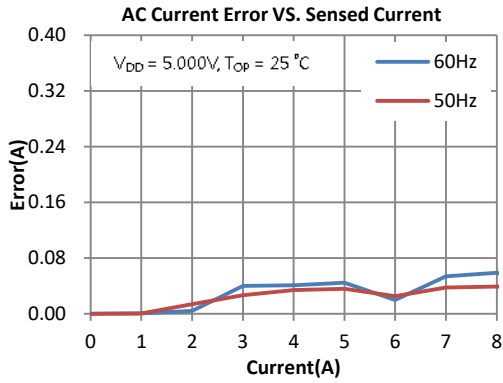

Winson reserves the right to make changes to improve reliability or manufacturability.

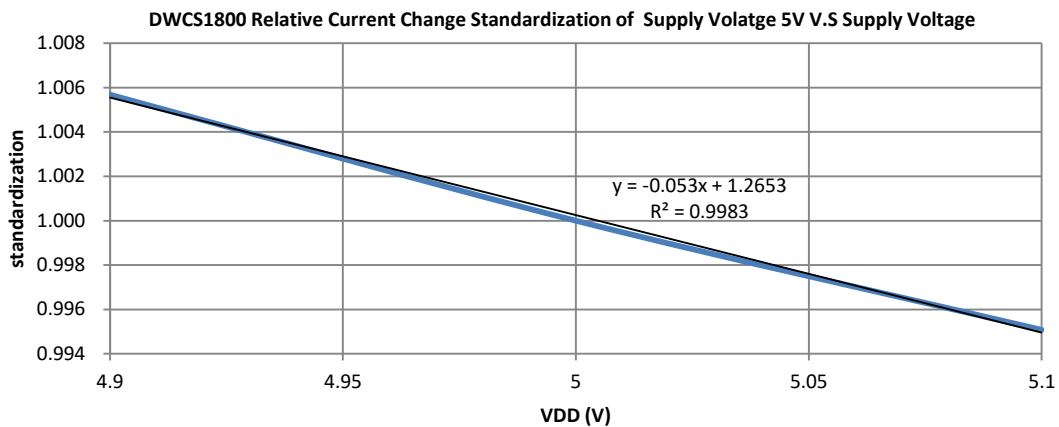

Application Note:

(1) Application Diagram:

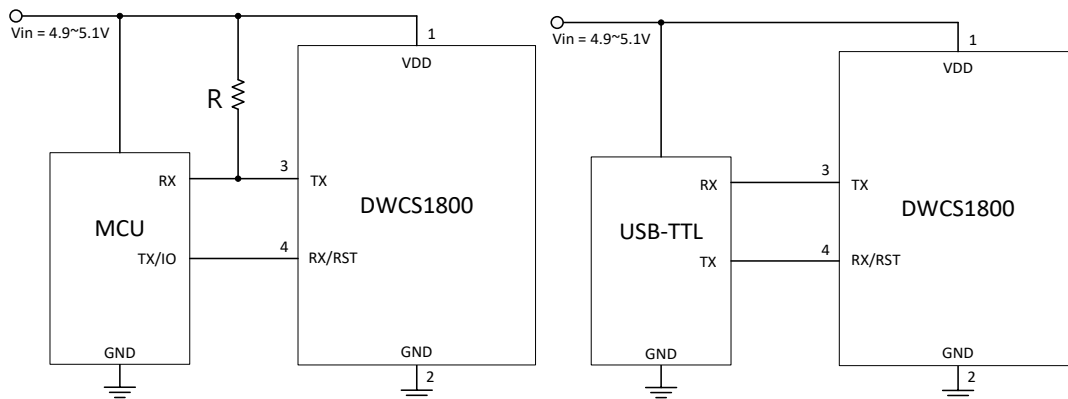

App. 1 Connect to MCU

App. 2. Connect to USB-TTL

(DWCS1800 TX needs open drain with external pullup resistors)

(2) Measured Current Data Output (Continuous & AT Command Version):

The measured current can be transmitted by UART format.

- (2.1) If the measured data is AC "1.23"A, then the output data is '~', '1', '.', '2', '3', '0', '\r', '\n', total of 8 bytes; the output data is ASCII code. If the measured data is "10.45" A, then the output data is '~', '1', '0', '.', '4', '5', '\r', '\n', total of 8 bytes.
- (2.2) If the measured data is +DC "1.23"A, then the output data is '+', '1', '.', '2', '3', '0', '\r', '\n', total of 8 bytes; the output data is ASCII code.
- (2.3) If the measured data is -DC "1.23"A, then the output data is '-', '1', '.', '2', '3', '0', '\r', '\n', total of 8 bytes; the output data is ASCII code.

Winson reserves the right to make changes to improve reliability or manufacturability.

(3) True RMS Current Measurement:

In order to calculate true RMS of AC current, you need to know “zero” value of AC current first. The “zero” value of symmetric AC current is the average value $V_o(dc)$ of the current shown in Figure 1.

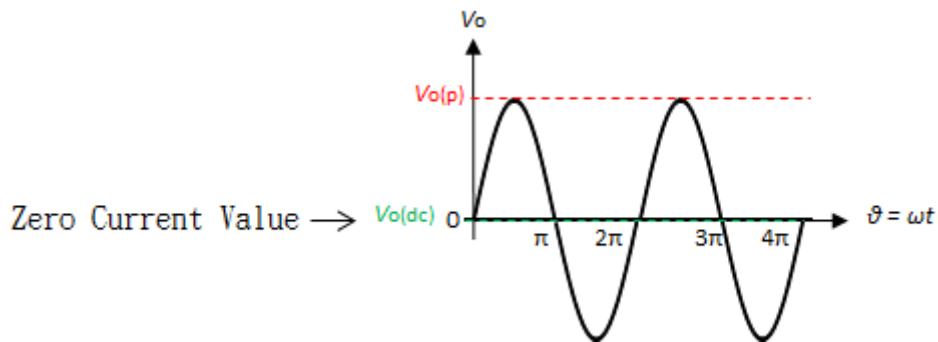

Figure 1 The zero current value of sine waveform

But in asymmetrical AC current, the “zero” value is not the average value $V_o(dc)$ of the current. Based on this “zero” value and do RMS calculation. You will get wrong answer.

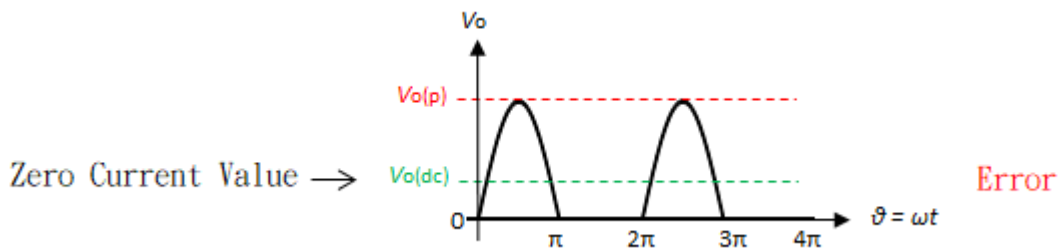

Figure 2 The zero current value of the asymmetric waveform (Error)

The DWCS1800 offers a true RMS solution for both symmetric and asymmetric AC current. It can correctly detect “zero” current value, shown in Figure 3. and do perfect RMS calculation.

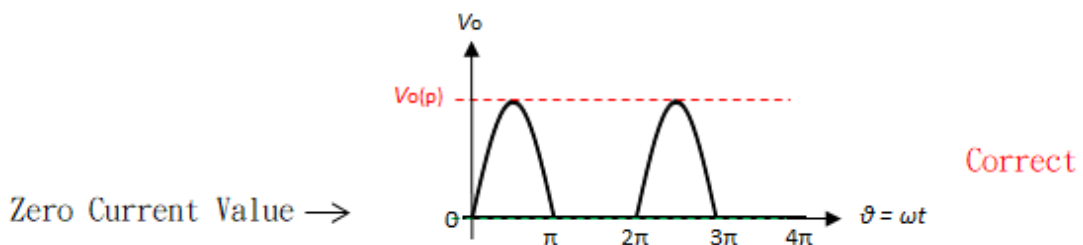

Figure 3 The zero current value of the asymmetric waveform (Correct)

(4) AT Command:

Setting Command	Command	Example	Return Parameter
Reset Current	AT+RST\r\n	"AT+RST\r\n"	"OK\r\n" ⁽¹⁾
0: DC 1: AC	AT+CURRE\r\n	"AT+CURRE,0\r\n" "AT+CURRE,1\r\n"	"OK\r\n" ⁽¹⁾
Measure Current	AT+MEAS\r\n	"AT+MEAS\r\n"	<Current>
Measure Temperature	AT+TEMP\r\n	"AT+TEMP\r\n"	<Temperature>

1. Command is error: return "Err\r\n" °

(5) Modbus-RTU Command:
(5.1) Modbus Parameter List

Item	Address	Byte	R/W	Description
Reset	0x0000	2	Write	Input 256 to Reset
Current	0x0002	4	Read	Hexadecimal signed (HEX), Unit:0.001A Current= HEX/1000 (A)
Temperature	0x0004	4	Read	Hexadecimal signed (HEX), Unit:0.1°C Temperature= HEX/10 (°C)
Slave Address ⁽¹⁾	0x0010	2	Write	Default address: 1 Input address1~247
DC/AC	0x0020	2	Write	0: DC 1: AC

1. Address will be memorized.

For more detail on Modbus-RTU description, please refer to the "DWCS Application Note"

(5.2) Modbus-RTU Data Format

Slave Address	Function Code	Data	Check Code (CRC16)
1 Byte	1 Byte	N x Byte	2 Byte (Low byte first)

Winson reserves the right to make changes to improve reliability or manufacturability.

(5.3) Function Code

Function Code	Description
03H	Read up to 125 continuous memory words
06H	Write one memory word

(5.4) Exception Code

Exception Code	Description
01H	Illegal function code
02H	Illegal data address
03H	Illegal data count

When responding to an exception, the MSB (Most Significant Bit) of the function code is automatically set to 1.

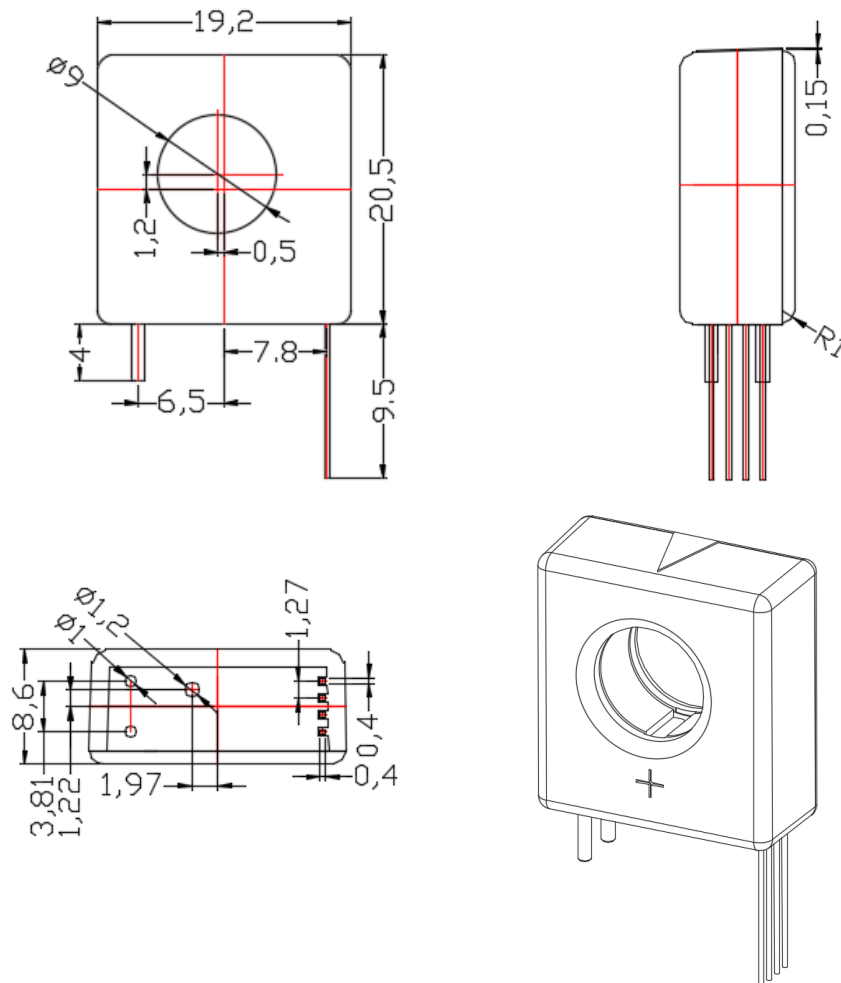
Package: (Units: mm)

Winson reserves the right to make changes to improve reliability or manufacturability.